

Владимирский государственный университет

СОВРЕМЕННЫЕ НАНОТЕХНОЛОГИИ
И НАНОФОТОНИКА ДЛЯ НАУКИ
И ПРОИЗВОДСТВА

Материалы 7-й Международной конференции

8 – 12 ноября 2018

Владимир 2018

Министерство науки и высшего образования Российской Федерации
Федеральное государственное бюджетное образовательное учреждение
высшего образования
«Владимирский государственный университет
имени Александра Григорьевича и Николая Григорьевича Столетовых»

СОВРЕМЕННЫЕ НАНОТЕХНОЛОГИИ И НАНОФОТОНИКА ДЛЯ НАУКИ И ПРОИЗВОДСТВА

Материалы 7-й Международной конференции

8 – 12 ноября 2018 г.,
г. Владимир – г. Суздаль

Электронное издание



Владимир 2018

©ВлГУ, 2018

ISBN 978-5-9984-0909-7

УДК 620.3

ББК 30.6

Редакционная коллегия:

- *Кутровская С. В.*, ст.научный сотрудник каф. ФиПМ (*председатель*);
- *Баринов В. В.*, электроник каф. ФиПМ;
- *Шагурина А.Ю.*, инженер каф.ФиПМ;
- *Самышкин В.Д.*, зав.лаб.каф. ФиПМ;
- *Бухаров Д.Н.*, ст.преподаватель каф. ФиПМ;
- *Истратов А.В.*, инженер-исследователь каф. ФиПМ;
- *Скрябин И.О.*, инженер-исследователь каф.ФиПМ;
- *Новикова О.А.*, инженер каф.ФиПМ;
- *Седова И. Е.*, инженер каф. ФиПМ;
- *Родина О. Л.*, зав. лаб. каф. ФиПМ;
- *Осотов А. Г.*, помощник проректора по ОВ и РМБ ИПМФИ.

Издается по решению редакционно-издательского совета ВлГУ

Современные нанотехнологии и нанофотоника для науки и производства : материалы 7-й Междунар. конф. 8 – 12 нояб. 2018 г., г. Владимир – г. Суздаль [Электронный ресурс] / Владим. гос. ун-т им. А. Г. и Н. Г. Столетовых. – Владимир: Изд-во ВлГУ, 2018. – 112 с. – Систем. требования: Intel, AMD от 1,3 ГГц; Windows XP/Vista/7/8/10; Adobe Reader; CD-ROM; 5 Мб. – Загл. с титула экрана.

В сборник включены материалы международной конференции, которая состоялась 8 – 12 ноября 2018 года в г. Суздале при поддержке Министерства науки и высшего образования Российской Федерации и Российского фонда фундаментальных исследований. Сборник содержит 56 статей более 200 авторов на темы: источники терагерцового излучения и их применение, нелинейная оптика и спектроскопия, квантовая и атомная оптика, методы синтеза и диагностики наноматериалов и наноструктур, новые углеродные материалы и их применение, нанофотоника.

Представляет интерес для специалистов в области фотоники и лазерной техники.

УДК 620.3

ББК 30.6

ISBN 978-5-9984-0909-7

© ВлГУ, 2018

© Коллектив авторов

CONTENTS

ABSTRACTS	9
1.CHAOTIC AND SUPERSOLID STATES OF CAVITY POLARITONS	
<i>S. Gavrilov</i>	10
2.NEW CHALLENGES OF FEMTO- NANOPHOTONICS: BASIC PRINCIPLES AND POSSIBLE APPLICATIONS	
<i>S. Arakelian, A. Kucherik, S. Kutrovskaya, A. Kavokin</i>	11
3.DYNAMICS OF RESONANTLY EXCITED EXCITON-POLARITON FLUIDS IN GAAS MICROCAVITIES IN THE ABSENCE OF AN EXCITON RESERVOIR	
<i>V. Kulakovskii, A. Demenev, A. Brichkin, S. Gavrilov and N. Gippius</i>	14
4.LASER SYNTHESIS OF NANOCRYSTALLINE CARBON AND CARBYNE IN LIQUIDS	
<i>A. Kucherik, A. Antipov, S. Kutrovskaya, A. Osipov, A. Povolotckii, A. Povolotckaia, S. Arakelian</i>	16
5.EXPERIMENTAL AND NUMERICAL STUDY OF LASER-INDUCED METAL NANOPARTICLE FORMATION IN THIN POROUS FILMS	
<i>Y. Andreeva, M. Sergeev, H. Ma, N. Sharma, N. Destouches, T. Itina and V. Veiko</i>	18
6.TEMPERATURE DEPENDENCE OF THE EXCITON LUMINESCENCE SPECTRA OF CDSE NANOCRYSTALS GROWN IN THE LIQUID-CRYSTAL MATRIX	
<i>K. Magaryan, A. Naumov, K. Karimullin, I. Vasilieva</i>	20
7.ЛАЗЕРНЫЕ ТЕХНОЛОГИИ СОЗДАНИЯ НАНОСТРУКТУРИРОВАННЫХ МАТЕРИАЛОВ И УСТРОЙСТВ НАНОЭЛЕКТРОНИКИ И ФОТОНИКИ	
<i>О. Новодворский, Л. Паршина, О. Храмова, А. Лотин, А.Шкуринов, В.Панченко</i> .	22
8.NANOSCALE STUDIES OF SMART AND FUNCTIONAL MATERIALS BY MEANS OF SCANNING PROBE MICROSCOPY	
<i>S.Leesment, A. Shelaev, V. Polyakov, V. Bykov</i>	23
9.HYBRID GOLD-SILICON SYSTEMS WITH TUNING OPTICAL PROPETIES	
<i>S. Kutrovskaya, A. Osipov, A. Shagurina, A. Kucherik</i>	24
10. STIMULATED LIGHT SCATTERING BY NANOPARTICLES	
<i>A. Masalov</i>	26

11. VITREOUS SILICA UPON LASER IRRADIATION: THE VIBRATIONAL MODES TREATMENT AND RAMAN ANALYSIS	
<i>N. Shcheblanov, M. Povarnitsyn</i>	27
12. HIGH-THROUGHPUT ATOMIC FORCE MICROSCOPY AND ITS APPLICATIONS	
<i>Y. Bobrov, P. Vinar, V. Atepalikhin, S. Leesment, V. Bykov, V. Polyakov</i>	28
13. THE REORIENTATION MECHANISM AND OPTICAL PROPERTIES OF HELIX-FREE FERROELECTRIC LIQUID CRYSTALS	
<i>I. Kompanets</i>	29
14. ELECTROMAGNETIC PROPERTIES OF POLYMER MWCNT-BASED COMPOSITES WITH ALUMINOSILICATE HOLLOW MICROSPHERES	
<i>D. Meisak, D. Bychanok, G. Gorokhov, J. Macutkevic, J. Banys and P. Kuzhir</i>	31
15. LASER SPECTROSCOPY METHODS FOR MEASURING OF LUMINESCENCE KINETICS	
<i>A. Povolotskiy</i>	32
16. FIBER BASED QUANTUM CRYPTOGRAPHY WITH POLARIZATION STATES	
<i>A. Duplinskiy, E. Kiktenko, V. Kurochkin, A. Fedorov, Y. Kurochkin</i>	33
17. CARBON NANOCOMPOSITES FOR 3D-PRINTING APPLICATIONS	
<i>G. Gorokhov, D. Bychanok, D. Meisak, I. Shlyk, A. Liubimau, P. Angelova, E. Ivanov, R. Kotsilkova, M. Casa, P. Ciambelli and P. Kuzhir</i>	34
18. OPTICAL SPIN ORIENTATION OF ELECTRONS AND NUCLEI IN SEMICONDUCTORS CONTROLLED BY SHOCKLEY–READ–HALL RECOMBINATION	
<i>V. Kalevich</i>	35
19. DIRECTED AND HIGHLY POLARIZED SPASING OF SILVER NANOPARTICLES FROM BENEATH THE THIN AMPLIFYING FILM	
<i>A. Kamaliev, N. Toropov, T. Vartanyan</i>	36
20. SITE-SELECTIVE SPECTROSCOPY OF QUANTUM-DOT-DOPED NANOCOMPOSITES	
<i>K. Karimullin, A. Arzhanov, K. Magaryan, A. Naumov</i>	37
21. СПЕКТРАЛЬНЫЕ СВОЙСТВА ЛАЗЕРНЫХ ПЛАНАРНЫХ ВОЛНОВОДОВ НА ОСНОВЕ ФТОРИДНЫХ КЕРАМИК И ТВЕРДЫХ	

PACTBOPOB	
<i>A. Федул, C. Cepzeev</i>	39
22. NANOSCALE ARCHITECTONICS OF NATURAL GRAPHENE-LIKE CARBON	
<i>N. Rozhkova, A. Kovalchuk, S. Rozhkov, A. Kucherik, A. Prihodko</i>	41
23. LASER TECHNOLOGY FOR LOW DIMENSIONAL NANOCUSTER PHYSICS	
<i>S. Arakelian, I. Chestnov, A. Kucherik, C. Kutrovskaya, A. Istratov, T. Khudaiberganov</i>	43
24. TRANSIENTS AND STEADY-STATES IN FLUORESCENCE FROM COLLECTIVE ENSEMBLES IN DIELECTRIC HOSTS	
<i>M. Gladush, N. Lozing, I. Eremchev, A. Naumov</i>	47
25. FORMATION OF A COLLECTIVE BOSONIC POLARON IN THE EXCITON POLARITON CONDENSATE	
<i>T. Khudaiberganov, I. Chestnov, A. Kavokin</i>	48
26. PHOTON ECHO AS A TECHNIQUE FOR DIAGNOSTICS OF LOW-TEMPERATURE DYNAMICS IN DISORDERED SOLIDS AND NANOCOMPOSITES WITH QUANTUM DOTS	
<i>K. Karimullin, A. Arzhanov, A. Naumov</i>	49
27. LASER SYNTHESIS OF THE WO₃ THIN FILMS FOR SOLID-STATE ELECTROCHROMIC CELLS	
<i>L. Parshina, O. Novodvorsky, O. Khramova, A. Lotin, P. Shchur</i>	50
28. FORMATION AND TRANSFER OF A TEST-OBJECT IMAGE BY LASER BRIGHTNESS AMPLIFIER WITH OPTICAL BUNCH	
<i>A. Galkin, S. Zhirnova, E. Shamanskaya</i>	52
29. HIGH-POWER X-RAY TUBE FOR MICRO COMPUTER TOMOGRAPHY (MCT)	
<i>E. Grachev, E. Kozlov, A. Trubitsyn</i>	54
30. MODELING THE CLUSTER STRUCTURE OF A BIMETALLIC FRACTAL AG/AU NANOFILM	
<i>D. Bukharov , A. Istratov, V. Samyshkin, A. Antipov, O. Novikova, S. Arakelian</i>	56
31. ANTI-COUNTERFEITING FRET BASED INVISIBLE INKS PRELIMINARY INVESTIGATIONS WITH RYLENIC ORGANIC DYES	
<i>C. Levi</i>	58

32. LIGHT EMITTERS FOR HIGH-SPEED OPTOELECTRONIC DIGITAL-TO-ANALOG CONVERSION	
<i>A. Bushuev, A. Zolotov, N. Davydov, D. Kochuev, R. Chkalov</i>	60
33. SIMULATION OF ELECTRICAL CONDUCTIVITY OF THE BIMETALLIC ISLAND OF THE AG/AU ISLAND NANOFILM	
<i>D. Bukharov, A. Istratov, V. Samyshkin, A. Antipov, O. Novikova, S. Arakelian</i>	62
34. TUNABLE ALEXANDRITE LASER	
<i>A. Antipov, A. Putilov</i>	64
35. LINE-BY-LINE FIBER BRAGG GRATING FABRICATION BY FEMTOSECOND LASER RADIATION	
<i>A. Chernikov, K. Khorkov, D. Kochuev, R. Chkalov, V. Prokoshev</i>	66
36. THE LASER SYNTHESIS AND DEPOSITION OF GaN NANOPARTICLES	
<i>I. Skryabin, V. Samyshkin, A. Osipov, S. Arakelian</i>	68
37. INVESTIGATION OF NONLINEAR PROPERTIES OF MATERIALS USING THE Z-SCAN TECHNIQUE AND FEMTOSECOND LASER RADIATION	
<i>M. Tarasova, K. Khorkov, D. Kochuev, R. Chkalov, V. Prokoshev</i>	69
38. RESEARCH OF THE ABSORPTION OF LASER RADIATION BY POWDER MATERIALS	
<i>S. Alexandrov, S. Usov, A. Voznesenskaya, A. Zhdanov, D. Kochuev</i>	71
39. МЕТОД ЭЛЕКТРО-ИНДУЦИРОВАННОЙ ЛИТОГРАФИИ В ЗАДАЧЕ НАБЛЮДЕНИЯ ТАММОВСКОГО ПЛАЗМОНА	
<i>A. Шагурина, A. Лелекова, A. Кель, С. Кутровская</i>	73
40. THE MEASUREMENTS OF LASER RADIATION PARAMETERS AT ITS REGISTRATION ON A DIFFUSELY REFLECTING SHIELD	
<i>A. Antipov, E. Artyukh, I. Boganova, A. Karpov, A. Morozova, A. Shepelev</i>	75
41. SYNTHESIS OF TITANIUM NANOTUBES DOPED WITH NPS OF NOBLE METALS	
<i>I. Skryabin, A. Kucherik, A. Osipov, S. Kutrovskaya</i>	77
42. LOCALIZATION OF AN ELECTRIC ARC DISCHARGE IN A LASER-INDUCED PLASMA CHANNEL	
<i>A. Ivashchenko, D. Kochuev, R. Chkalov, K. Khorkov, V. Prokoshev</i>	79
43. FORMATION OF ANTIFRICTION SURFACE-PERIODIC NANOSTRUCTURES UNDER THE ACTION OF ULTRASHORT LASER PULSES	
<i>A. Voznesenskaya, D. Kochuev, A. Zhdanov, K. Khorkov, V. Morozov</i>	81

44. PHOTOACOUSTIC INVESTIGATION OF ABLATION DYNAMICS DURING DOUBLE-PULSED FEMTOSECOND LASER PROCESSING OF SILICON AND ALUMINUM	
<i>Y. Golubev, A. Samokhvalov, D. Polyakov, S. Shelygina and V. Veiko</i>	83
45. THE LASER-ASSISTED SYNTHESIS OF LINEAR CARBON CHAINS STABILIZED BY NOBLE METAL PARTICLES	
<i>A. Osipov, A. Kucherik, S. Kutrovsкая, I. Skryabin, S. Arakelian</i>	84
46. STRONGLY-COUPLED ELECTRON AND NUCLEAR SPIN SYSTEMS IN INGAAS EPILAYERS	
<i>A. Evdokimov, M. Kuznetsova, M. Petrov, Y. Efimov, S. Eliseev, V. Lovtcius, P. Shapochkin</i>	86
47. SELECTED TOPICS FROM NON-IDEAL STRUCTURE POLARITONICS	
<i>V. Rumyantsev, S. Fedorov, A. Kavokin</i>	88
48. MODEL OF DIFFUSION PACKING COLLOIDAL PARTICLES	
<i>A. Istratov, D. Bukharov, V. Samyshkin, M. Gerke, S. Arakelian</i>	90
49. SYNTHESIS AND CHARACTERIZATION OF NEW HYBRID MATERIAL BASED ON MWCNTS DECORATED WITH TITANIUM CARBIDE NANOCOATINGS WITH DIFFERENT MORPHOLOGY AS REINFORCING COMPONENTS OF ALLOYS	
<i>A. Aborkin, K. Kremlev, A. Obiedkov, B. Kaverin, N. Semenov, G. Zabrodina</i>	93
50. FORMATION OF FRACTAL CRYSTALS ON STEEL SURFACE	
<i>A. Burtsev, D. Bukharov, E. Pritotsky, A. Pritotskaya, M. Shakhov, N. Aganin, O. Butkovsky</i>	95
51. EFFICIENT FREQUENCY DOUBLING ON WITH THE THREE-MIRROR RESONATOR	
<i>E. Pritotsky, S. Lysenko, M. Pankov</i>	97
52. PHYSICAL PROPERTIES OF NANODEFECTED SURFACE THIN-FILM STRUCTURE	
<i>A. Burtsev, E. Pritotsky, M. Pankov</i>	99
53. FORMATION OF THE CHROMATICITY ON STEEL SURFACE	
<i>E. Pritotsky, A. Pritotskaya, A. Burtsev, O. Butkovsky</i>	100
54. FORMATION OF CHANNELS WITH CHANGED REFRACTIVE INDEX AT THE FILAMENTATION OF FEMTOSECOND LASER RADIATION IN QUARTZ	

GLASS

M. Tarasova, K. Khorkov, D. Kochuev, V. Prokoshev, A. Ivaschenko 102

**55. МОДИФИКАЦИЯ СКОРОСТИ ГЕНЕРАЦИИ ПОВЕРХНОСТНЫХ
ПЛАЗМОН-ПОЛЯРИТОНОВ ВОЗБУЖДЕННЫМИ
ПОЛУПРОВОДНИКОВЫМИ КВАНТОВЫМИ ТОЧКАМИ ВБЛИЗИ
МЕТАЛЛИЧЕСКОЙ ПОВЕРХНОСТИ**

A. Шестериков, М. Губин, М. Гладуш, А. Прохоров 104

56. LASING CHARACTERISTIC OF LASER CERAMICS

M. Pankov, S. Lysenko, A. Kanaev, A. Kiselev, A. Antipov 107

CONFERENCE INFORMATION AND CONCLUSION 108

ABSTRACTS

1. CHAOTIC AND SUPERSOLID STATES OF CAVITY POLARITONS

S. Gavrilov

Institute of Solid State Physics RAS, Chernogolovka, 142432, Russia

gavr_ss@issp.ac.ru

Cavity polaritons are composite bosons formed owing to the strong coupling of excitons and cavity photons. They are excited optically and emit light. The lifetimes of polaritons in GaAs-based microcavities lie in the picosecond range, however they form macroscopically coherent (Bose condensate) states under optical driving.

In the case of resonant driving, interaction between polaritons results in various collective phenomena, multistability, parametric scattering, etc. Typically, nonequilibrium transitions occur in a threshold manner upon varying external conditions. Apart from a few number of critical points, polaritons were long thought to follow the driving force adiabatically and, for instance, the state of a homogeneous polariton system driven by a constant plane wave was thought to be also constant. However, coupling between spin components has recently been found to result in nonstationary and, in particular, chaotic polariton states [1].

Paradoxically, turbulence (chaoticity) goes hand in hand with strong spatial ordering. When the condensate is forbidden to match the symmetry of the external field [2], the system gets rid of strict phase locking and the possibilities open up for both ceaseless variation in a constant environment and the secondary—internal—ordering of the system. In particular, a quasi-one-dimensional (1D) microcavity wire arranges itself into a network of spin-up and spin-down domains alternating each other in a strict order. Furthermore, if a particular spin in such a chain is reversed manually, e.g., by means of an additional properly focused laser beam, under certain conditions all other spins also get reversed with time, no matter how remote they are [3].

Thus, the internally ordered polariton network resembles a crystal rather than a fluid. Similar structures could arise in a periodic potential inducing a lattice of coupled condensates. Today they are often referred to as supersolid states [4], implying a non-dissipative (“superfluid”) propagation of excitations through such a lattice. We have found that polariton networks also exhibit characteristic “vacancies”—bright or dark solitons—which flow without dissipation and alter their spin states at each node of the network. It is noteworthy, however, that in our case the lattice itself appears out of a perfectly homogeneous Bose gas due to spontaneous symmetry breaking.

This work was supported by the RFBR, grant No. 16-02-01172.

- [1] S. S. Gavrilov, *Phys. Rev. B* 94, 195310 (2016)
- [2] S. S. Gavrilov, *JETP Lett.* 105, 200 (2017)
- [3] S. S. Gavrilov, *Phys. Rev. Lett.* 120, 033901 (2018)
- [4] J. Léonard et al., *Nature* 543, 87 (2017)

2. NEW CHALLENGES OF FEMTO- NANOPHOTONICS: BASIC PRINCIPLES AND POSSIBLE APPLICATIONS

S. Arakelian¹, A. Kucherik¹, S. Kutrovskaya¹, A. Kavokin²

¹Stoletovs Vladimir State University, Gorky Str. 87, Vladimir 600000, Russia

²University of Southampton, England.

1. The physical properties of nanocluster systems are very sensitive to the form, size and distance between their composing elements. The fact is very well known for any material in general, but to change these parameters and to carry out the stable conditions for ordinary solid state object we need both to put the object under extremal high pressure ($\geq 10^6$ atm) and to work in low (liquid He) temperature range ($\lesssim 30$ K).

In contrast, the nanocluster structures of thin films can be easily modified in necessary direction, and especially by controllable way in the femto- nanophotonics experiments [1]. The variation of the enumerated above topological parameters can result in new type of quantum correlation states for charged particles. Moreover, the electronic energetic bands of the materials can vary dramatically in the case, resulting in new physical behavior of the system in both electrophysics and optical response [2,3].

In superconductor problem the principal question usually is how to fabricate the coupling states (around the forbidden band) at high (usually nitrogen) temperature (≥ 140 K) for charged particles being responsible for electroconductivity. Some alternative mechanisms of electron coupling for nanocluster system (not via standard phonon coupling) may be realized in general.

2. We applied several laser procedures with different pulse duration (from cw to fs) to obtain the nanostructures and thin films with controllable topology. Namely, in addition to the direct laser modification of solid surfaces, we used, first, the laser ablation of targets in liquid to obtain colloidal systems and, second, to deposit the nanoparticles from the colloid on a solid surface for formation of nanostructures in necessary way by two technique: the laser radiation action and the droplet falling from the nozzle.

3. We studied in both theory and experiment the laser-induced nanocluster structures of different types (in topology and element composition) taking into account the correlations in nanoparticle ensemble by quantum states. The problem of high temperature superconductivity due to topological surface structures (resulting in coupled states on new dimensional principles) are under our consideration.

We discuss the three fundamental factors for functional properties of the nanocluster system: the dependence on size including the quantum size effects for nanostructures with characteristic spatial scales of ~ 10 nm (number of atoms $\lesssim 10^3$); surface nanostructures with different defects including boundary conditions that determines the phase transitions in inhomogeneous layers (1–100 nm); nearfield effects with local extreme values of key physico-chemical parameters for low-dimensional inhomogeneous structures.

On the other hand, such a sensitivity of electronic properties to the topology of cluster system may be equivalent to the doping of semiconductor materials, and can be used as an effective instrument to control the electroconductivity of the system. In fact, high level of

doping (resulting in high electroconductivity) can be replaced by adjustable topology structure of the nanocluster sample.

All these factors must be considered to study the functional/physical properties of the laser-induced micro- nanostructured composite materials, and are under our discussion.

4. In our experiments the current-voltage characteristics (CVCs) of thin films were measured using a four probe technique. Two external contacts were used to supply the power voltage; the distance between them was $L = 1$ mm. Two middle (for measuring) microcontacts were conductive probes of the atomforce microscope used for diagnostics. During the measurements they were scanned across of a sample surface; the maximum distance between these contacts was no more than $100 \mu\text{m}$. External voltage was applied in both longitudinal and transverse directions relatively to the length of the substrate, and was ranged from 0.1 to 1 V with an increment of 0.05 V. Thus, the magnitude of the external electric field was ranged from 10^2 to 10^3 V m^{-1} .

In electrophysics experiment, we have seen competition between increase electroconductivity, while opening new channels in a spatially inhomogeneous charged structure, and increase the resistance by increasing of the areas between the conductive grains. Such electrical transport properties (due to quantum correlated states resulting in two mechanisms of electroconductivity: tunnel and hopping electroconductivities) may be presented as a special type of topological electrophysical surface structures (both localized and delocalized coupled states for charged carriers in granulated structure). Dramatic enhancement of electroconductivity (in several orders) has been observed in our experiments due to variation of topological peculiarities of a nanocluster thin film system.

Thus, we obtained in electroconductivity: the tunneling delocalized effect which depends on the size of nanoclusters (with controlled both distance between them and shape of tunnel barriers, by variation of the thickness of the films and, as well, due to transition from amorphous to crystalline structure occurring under some conditions) the thermally activated hopping regimes of the electronic transport between localized centers; the topology superconducting cluster tendency in analogy with topological insulators.

5. The principal items for the high temperature superconductivity problem are under our discussion.

First, to understand both the mechanism and tendency to have the coupling for electrons: via phonons, polaritons, excitons, magnons and dimensional effects. In fact, some processes (forbidden in monolithic samples) arise in nanosystems because of the size effects: a Cooper-pair may occur near the boundaries/surface, e.g. via individual interaction of charged particles under topology peculiarities; for a spin-flip processes of electrons when they are associated in localized coupled states; a very simple Bose-like construction of Fermi-clusters arises via variation of distance being a self-occurring adjustable parameter in respect of minimal energy between the cluster carriers.

Second, to analyze the specific manifestation of superconductivity in complex system (both in composition and topology): the electroresistance behavior itself; the Meissner effect development; a space distribution of the current trajectories integrated over cross-section.

Third, in superconductor state of the medium there are two types of electrons – coupling and ordinary. It is necessary to separate these two different regimes. But the electron flow is

realized in optimal way only – when a minimal electroresistance (like short-circuit current) occurs.

Fourth, to recognize in details the interrelationship between the electronic energetic shell structure and opportunity of the pair correlation arising in metallic nanoclusters for both isolated nanoclusters and cluster network.

6. As to optical properties, e.g. for bimetallic (Au+Ag) films, we demonstrated that it is possible to control both the plasmon resonance behavior and propagating plasmon waves due to inhomogeneous structure (being a random manifestation of special schemes for travelling waves). Absence of narrow plasmon resonance is namely due to inhomogeneous nanostructures. In experiment we have seen several effects: the broadening of electronic levels; variation of optical metasurfaces characteristics; development of strong optical response; variation of density of e-state (on Fermi-surface). In addition, we observed the formation of the artificial meso-atom nanostructures when a positive nucleus (being the Si-atom) is covered by negative charged Au-atoms. Such objects may be presented as a shell-like dot structure, and the modelling of their unusual structures and optical properties has been carried out by us for different conditions.

7. Obtained results give us an opportunity to establish the basis of new physical principles to create the functional elements for optoelectronics and topological photonics in hybrid set-up (optics + electrophysics) by the different topology controllable nanoclusters with dramatic change of both electroconductivity and optical response vs spatial structure of nanoclusters in thin films at room temperature.

This work is supported by RFBR grants 16-42-330461 r_a and by the grant of president of Russian Federation by project MK-2842.2017.2.

[1] Arakelian, S.M., Kucherik, A.O., Prokoshev, V.G., et al., Introduction to Femtonanophotonics: Fundamentals and Laser Methods for Controlled Fabrication and Diagnostics of Nanostructured Materials, Arakelian, S.M., Ed., Moscow: Logos, 2015, 744 P.

[2] Kavokin A. V., Kutrovskaya S. V., et. al. The crossover between tunnel and hopping conductivity in granulated films of noble metals. Superlattices and Microstructures V. 111, Nov. 2017, P. 335-339.

[3] Kutrovskaya S. V., Arakelian S. M., et. al. The Synthesis of Hybrid Gold- Silicon Nano Particles in a Liquid. Scientific Reports 7: 10284 (6 pp.), Aug 2017.

3. DYNAMICS OF RESONANTLY EXCITED EXCITON-POLARITON FLUIDS IN GAAS MICROCAVITIES IN THE ABSENCE OF AN EXCITON RESERVOIR

V. Kulakovskii^{1,}, A. Demenev¹, A. Brichkin¹, S. Gavrilov¹
and N. Gippius²*

1 Institute of Solid State Physics, RAS, Chernogolovka, 142432 Russia

2 Skolkovo Institute of Science and Technology, Skolkovo, Moscow reg., 143025 Russia

** E-mail:kulakovs@issp.ac.ru, Tel - +7-926-5546652*

Exciton polaritons in semiconductor microcavities (MCs) are half-light-half-matter boson quasiparticles occurring due to strong coupling of the optical and exciton modes. They have attracted broad interest during the last decade. Until recently, most studies of lower polariton (LP) systems were carried under nonresonant excitation. An array of spectacular phenomena was discovered in these systems, which are characteristic of Bose-Einstein condensates. That enables to treat them as a dynamic Bose-Einstein condensate which has many features related with finite lifetime and interaction with exciton reservoir which ensures the influx of particles into the decaying condensate. The freely evolving resonantly excited polariton condensate at the LP branch bottom was found to retain coherence during tens of ps, which has allowed one to observe superfluidity in resonantly excited LP fluids[1], dark solitons and their decay into streets of quantized vortices[2,3]

In this work we investigated the dynamics of a freely decaying finite-sized LP fluid in high-Q MCs excited resonantly by ps-long light pulses both at zero wavevector k , and in a wide k -range with the aim to study the dynamics of the coherence, polarization, as well as spatial (r) and k -distributions of LPs in the pure LP fluid in the absence of an exciton reservoir.

We have found that LP fluids excited resonantly with coherent Gaussian beams inherit high coherence and polarization from the laser pulse and retain it during the decay both under the excitation at $k=0$ and in a wide k -range, i.e. any incoherent LP scattering is negligible when an exciton reservoir is absent. As a result, the temporal evolution of the fluid is uniquely determined by the r - and k -distributions of LPs initially inherited by them from the exciting laser pulse.

LP fluid with a wide k -distribution of LPs created by coherent convergent pulses of a large-aperture Gaussian beam in the MC located in front of the beam waist is found to be quickly, during several ps, dynamically compressed into a condensate state at the LP branch bottom with a spatially uniform phase.[4] This state persists for several ps until the repulsive interaction of LPs becomes dominant and leads to its expansion in both real and momentum spaces.

An incoherent LP system excited resonantly in a wide range of k -vectors by incoherent laser pulses acquires spatial coherence very slowly: the maximum value of the first-order correlation function $g(1)$ ($|r_1-r_2| = 10 \mu\text{m}$) in a highly excited LP system does not exceed 0.2 during 50 ps. An attempt to reduce markedly the condensation time by stimulating the $k=0$ state by an additional coherent laser beam pulses has not succeeded. Thus, the LP-LP scattering is not the primary mechanism of Bose-Einstein condensation and, therefore, the short

condensation time observed in nonresonantly excited MCs should be attributed to incoherent scattering of LPs within the exciton reservoir.

- [1] A. Amo, et al *Nature Phys.* 5, 805 (2009).
- [2] G. Grosso et al 107, 245301 (2011),
- [3] G. Nardin et al *Nature Phys.* 7 635 (2011)
- [4] V. D. Kulakovskii et al *JETP Letters*, 106, (2017).

4. LASER SYNTHESIS OF NANOCRYSTALLINE CARBON AND CARBYNE IN LIQUIDS

*A. Kucherik¹, A. Antipov¹, S. Kutrovskaya^{2,1}, A. Osipov¹, A. Povolotckii³,
A. Povolotckaia³, S. Arakelian¹*

¹A.G. and N.G. Stoletov Vladimir State University (VSU), 87 Gorki st., Vladimir, Russia, 600000

²Institute of Natural Sciences, Westlake University, No.18, Shilongshan Road, Cloud Town, Xihu District, Hangzhou, China

³Saint-Petersburg State University (SPbSU), Universitetskaya 7/9, Saint-Petersburg, Russia, 199034
E-mail: kucherik@vlsu.ru

New metal–carbon composite materials synthesized by laser irradiation of colloidal systems consisting of carbon and noble metal nanoparticles, are promising objects to realize surface-enhanced Raman scattering. The dependence of the Raman scattering intensity of the material composition has been investigated.

Introduction

The creation of new hybrid and composite materials based on carbon structures and metal nanoparticles is the most prospective area of nanotechnology. Carbon quantum dots demonstrate a variation of optical properties depending on the degree of crystallization, size and shape. The amplification of the observed phenomena can be realized by the addition of the noble metal nanoparticles, which have a plasmon resonant peaks in the visible region. The linear carbon chain (carbyne) is the promising carbon material for the creation of the hybrid and composite materials.

The strategy to incorporate metal nanoparticles in a carbon matrix is a great method to integrate the different properties to various materials, enabling to realize multifunctional composites. Such materials may be used in advanced applications like nanobiotechnology, optoelectronics, etc. In particular, a widely used approach is given by the combination of linear carbon chains and metals. In effect, linear carbon chain is the one of the most promising materials because of its unique physical and chemical properties and wide potential applications in nanophotonics. The possibility to obtain composites with large visible photoluminescence spectra for optoelectronic devices becomes especially interesting.

In this paper we presented a new experimental realization by the two-stage laser-induced synthesis of long linear carbon chain [1]. In our experiments, the proposed method is based on the laser irradiation of colloidal systems composed of shungite nanoparticles. This a two stage technique boils down to the following: (1) a colloidal system prepared beforehand by laser ablation from target shungite in distilled water using YAG:Nd³⁺ laser (1.06 μm) with a pulse duration of 1 ms and a pulse energy of up to 10 J [2]; (2) next, such colloidal system consisted carbon and metal particles [3] irradiated by Yb-fiber laser (1.06 μm) with a pulse duration of 100 ns and a pulse energy of up to 1mJ, and the process results in the fabrication of metal-carbyne materials. The mechanism for that is due to the homogeneous symmetry interaction in liquid for the carbon system that stabilizes the linear structure.

It was shown that this irradiation leads to the formation of clusters, in which metal nanoparticles are interrelated by carbyne chains. The Raman spectra of these structures exhibit SERS and depend significantly on the variation of metal particles concentration in colloidal system [4].

Raman and UV/VIS absorption spectra were measured at Center for Optical and Laser Materials Research, St. Petersburg State University.

The reported study was supported by the Ministry of Science and Higher Education of the Russian Federation (state project no. 16.5592.2017/6.7), RFBR grants # 16-42-330531r_a.

- [1] Kucherik A.O., Arakelian S.M., Garnov S.V. Two-stage laser-induced synthesis of linear carbon chains *Quantum Electronics*, 46:7 (2016), 627–633
- [2] Antipov A.A., Arakelian S.M., Garnov S.V. et al Laser ablation of carbon targets placed in a liquid// *Quantum electronics* Volume 45, Issue 8, 2015, Pages 731-735
- [3] Arakelyan, S.M., Veiko, V.P., Kutrovsкая et al Reliable and well-controlled synthesis of noble metal nanoparticles by continuous wave laser ablation in different liquids for deposition of thin films with variable optical properties// *Journal of Nanoparticle Research*, Vol. 18, 155, 2016
- [4] Kucherik A, Arakelina S. Vartanyan T. Laser-induced synthesis of metal–carbon materials for implementing surface-enhanced Raman scattering//*Optics and spectroscopy* Volume 121, Issue 2, 1 August 2016, pp. 263-270

5. EXPERIMENTAL AND NUMERICAL STUDY OF LASER-INDUCED METAL NANOPARTICLE FORMATION IN THIN POROUS FILMS.

Y. Andreeva^{1*}, M. Sergeev¹, H. Ma², N. Sharma², N. Destouches², T. Itina^{*1,2} and V. Veiko¹

¹ ITMO University, Kronverkskiy Pr. 49, St. Petersburg 197101, Russia

² Laboratoire Hubert Curien, UMR CNRS 5516, Université Jean Monnet, Université de Lyon, 42000, France

Mail: tatiana.itina@univ-st-etienne.fr and andreeva.ym@gmail.com

During recent decades nanoscale materials attracted continuously increasing interest. Among various perspective materials, particular attention was attracted by thin nanocomposite materials based on porous films doped with metallic nanoparticles. Such material possesses promising optical properties and high stability. Among other methods laser fabrication of such materials has several advantages, such as flexibility of processing parameters and high localisation of an affected area [1,2].

Clear understanding of the growth mechanism of NPs in such porous matrixes as well as effects associated with this process allows materials fabrication with unique optical and electromagnetic responses. Thus, here we present our experimental and numerical results obtained during metal NPs formation in SiO₂ and TiO₂ porous films CW laser irradiation. In particular, the effects of temperature distribution on growth kinetics and particle diffusion are discussed. We also analyse optical properties of the obtained nanocomposite material and check the possibility of self-organisation effects in the film.

To describe the underlying effects, we utilize an extended 2D model based on a combination of the heat conduction equation with the nonlinear growth kinetics of NPs. According to our calculations, the density and size distributions of the initial nanoparticles play significant roles in the kinetics of NPs formation due to the size-dependent absorption. Our model can also describe the unexpected experimental result, such as the higher temperature increase observed for higher scanning speed. Because even a very small temperature rise ahead of focal spot leads to changes in NPs size, the spatial distribution of laser energy absorption is considerably affected (Fig. 1).

Optical response of such structures depends on both the mean size and size distribution of NPs. The transmission and absorbance analysis of the obtained film showed a good agreement with the numerical results.

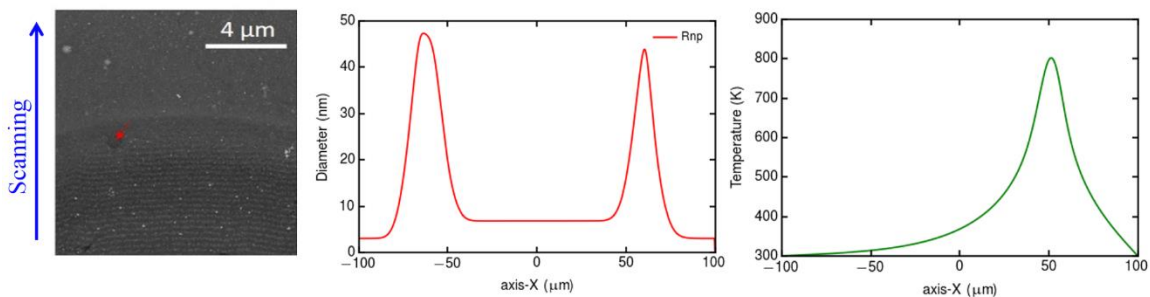

Figure 1 (a) – Experimental results showing self-organisation of Ag NPs in TiO₂; and (b) and (c) – calculation results obtained for CW laser power P=210mW, spot size D = 20μm, and scanning speed of V_s = 50μm/s.

The most interesting effect can be obtained when NPs are self-organized and form grating-like periodical structures [1,2]. This type of structures is related to the waveguide modes arising in the film due to laser irradiation with the specific parameters. The formation of periodical arrays of Ag NPs in TiO₂ films is demonstrated under laser irradiation with various scanning speed, and the observed dichroic effects are discussed.

[1] Liu Z. et al. Understanding the growth mechanisms of Ag nanoparticles controlled by plasmon-induced charge transfers in Ag-TiO₂ films //The Journal of Physical Chemistry C. – 2015. – T. 119. – №. 17. – C. 9496-9505.

[2] Liu Z. et al. Laser induced mechanisms controlling the size distribution of metallic nanoparticles //Physical Chemistry Chemical Physics. – 2016. – T. 18. – №. 35. – C. 24600-24609.

6. TEMPERATURE DEPENDENCE OF THE EXCITON LUMINESCENCE SPECTRA OF CDSE NANOCRYSTALS GROWN IN THE LIQUID-CRYSTAL MATRIX

K. Magaryan^a, A. Naumov^{a,b}, K. Karimullin^{a,b}, I. Vasilieva^a

^a*Moscow State Pedagogical University, 1/1 M. Pirogovskaya Str., Moscow, 119991 Russia*

^b*Institute of Spectroscopy RAS, 5 Fizicheskaya Str., Troitsk, Moscow, 108840 Russia*

tel.: +7 903 138 24 32, e-mail: ka.magaryan@mpgu.su

The temperature dependences of the maxima positions of the exciton bands in the luminescence spectra of the liquid-crystalline nanocomposites with CdSe 1.8 nm and 2.3 nm quantum dots at $T = 77 - 300$ K are studied. From the obtained results it is possible to calculate the values of the Huang-Rhys factor and the average phonon energy of the nanocrystals.

The objects under study are nanocomposites with CdSe nanocrystals (or quantum dots). CdSe nanocrystals with the size of 1.8 nm and 2.3 nm were grown in the ionic liquid crystalline matrix of cadmium alkanoate using template method of synthesis [1]. It's quite a new method of synthesis to grow quantum dots inside liquid crystalline host medium.

In our previous research [2] we described the luminescence peaks behavior in the wide range of low temperatures. With the temperature decrease, the maxima of exciton luminescence peaks shift to the UV spectral range. Such phenomenon is described taking into account influence of the processes of electron-phonon (exciton-phonon) interactions. The temperature shift of the exciton peak can be described using the Varshni equation [3], which later was modified by O'Donnell and Chen [4]:

$$E_g(T) = E_g(0) - \frac{2SE_{LO}}{\exp\left(\frac{E_{LO}}{K_B T}\right) - 1} \quad (1)$$

Here $E_g(0)$ is the band gap (the position of the first exciton maximum at 0 K), S is the Huang-Rhys factor responsible for the force of the electron-phonon interaction in the nanocrystal, E_{LO} is the average phonon energy, K_B is the Boltzmann constant.

Approximation of temperature dependences of the position of the exciton peaks in the luminescence spectra is shown at the figure 1. Using modified Varshni equation it is possible to estimate the corresponding parameters of the studied nanocrystals:

1. For nanocrystals with the size of 1.8 nm:

$$E_g(0) = 2.78 \text{ eV}; S = 7.1; E_{LO} = 71 \text{ meV.}$$

2. For the first exciton maximum for quantum dots with the size of 2.3 nm:

$$E_g(0) = 2.48 \text{ eV}; S = 4.1; E_{LO} = 46 \text{ meV.}$$

The model that takes into account the electron-phonon interaction made it possible to quantitatively describe the temperature dependences of the exciton luminescence spectra of quantum dots grown inside the liquid crystalline matrix, as well as to determine the values of the Huang-Rhys factor and the average energy of phonons for two sizes of nanocrystals. When describing the temperature behavior of the position and width of the luminescence spectra of impurity centers, as a rule, the interaction of the electron transition of the impurity with

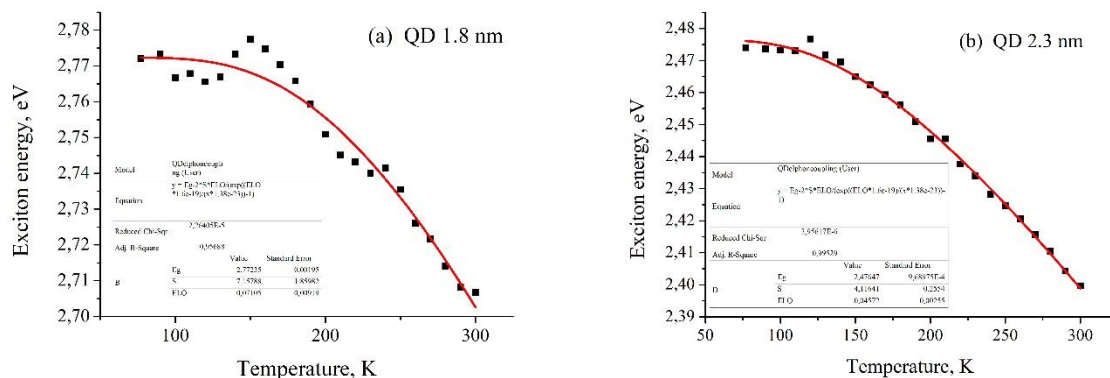

Fig.1. Temperature dependences of the position of the first maximum in the luminescence spectra (exciton energy) of nanocomposites with quantum dots of 1.8 nm (a) and 2.3 nm (b) – dots, their approximation (red solid lines) using the formula (1).

vibrational excitations (phonons) in the matrix is considered. The parameters obtained here by the numerical simulation of the luminescence spectra temperature dependence are in the good agreement with the experimental results, which indicates at the correctness of the selected model.

- [1] Zhulai D., Fedorenko D., Kovalchuk A., Bugaychuk S., Klimusheva G.V., Mirnaya T.A. // NRL. 2015. V. 10. P. 66
- [2] Magaryan K. A., Mikhailov M. A., Vasilieva I. A., Karimullin K. R., Klimusheva G. V. // Bull. RAS. Phys. 2014. V. 78. No 12. P. 1336.
- [3] Varshni Y. P. // Physica (Utrecht) 1967. V. 34. P. 149
- [4] Wen X., Sitt A., Yu P., Toh Y. R., Tang J. // Phys. Chem. Chem. Phys. 2012. V. 14. No 10. P. 3505

7. ЛАЗЕРНЫЕ ТЕХНОЛОГИИ СОЗДАНИЯ НАНОСТРУКТУРИРОВАННЫХ МАТЕРИАЛОВ И УСТРОЙСТВ НАНОЭЛЕКТРОНИКИ И ФОТОНИКИ

*О. Новодворский, Л. Паршина, О. Храмова, А. Лотин, А. Шкуринов,
В. Панченко*

*ИПЛИТ РАН - филиал Федерального государственного учреждения «Федеральный
научно-исследовательский центр «Кристаллография и фотоника» Российской
академии наук», 140700 Шатура, Россия
+79169028160 onov@mail.ru*

Рассмотрены методы получения наноструктурированных материалов и устройств нанoeлектроники и фотоники с использованием технологии импульсного лазерного осаждения.

1. Плазмонные структуры с использованием наночастиц, полученных при лазерной абляции.

2. Материалы для спинтроники: разбавленные магнитные полупроводники SiMn; ZnCoO; Наноструктурированные магнитные полупроводники GaSb:Mn, InSb:Mn.

2.1. Высокотемпературные ферромагнетики для создания быстрой энергонезависимой памяти.

2.2. Суперчувствительные датчики магнитного поля на магнитном полупроводниковом гетеропереходе p-InMnSb/n-InSb.

3. Прозрачные проводящие покрытия оксидов металлов In₂O₃:Sn; ZnO:Al(Ga); SnO₂:Sb на монокристаллических, аморфных и гибких органических подложках.

4. Мемристорные структуры с применением TiO₂, VO₂, ZnO:Co в качестве активных слоев.

5. Светоизлучающие гетероструктуры на базе ZnO и тройных растворов Mg_xZn_{1-x}O и Cd_yZn_{1-y}O.

6. Множественные квантовые ямы Mg_xZn_{1-x}O/ZnO и лазерная генерация при оптической накачке таких структур.

7. Генерация терагерцового излучения в пленках диоксида ванадия VO₂ при оптической накачке.

8. Электрохромные пленки оксида вольфрама.

9. Характеристики метода импульсного лазерного напыления. Управление энергией частиц в лазерном факеле при абляции твердых мишеней.

9.1. Управление энергией ионов при взаимодействии пересекающихся факелов.

10. Лазерное текстурирование мульткристаллического кремния.

8. NANOSCALE STUDIES OF SMART AND FUNCTIONAL MATERIALS BY MEANS OF SCANNING PROBE MICROSCOPY

S.Leesment, A. Shelaev, V. Polyakov, V. Bykov

*NT-MDT Spectrum Instruments, Proezd 4922, 4/3 Zelenograd,
Moscow, Russian Federation
leesment@ntmdt-si.com*

High interest to smart and functional materials is gained due to their promising applications including use in development for automotive, constructive, aerospace, machine, memory storage, sensor/actuator, energy harvesting, health monitoring and biomimetic devices. The capability of active and adaptive response to the stimuli and increased durability increases the efficiency and reduces the cost of the final products as well as brings the capability to develop the new advantaging solutions.

Materials study at micro- and nanoscale allows to understand the original background of materials properties at macroscale. Scanning probe microscopy (SPM) is the direct instrument for studies of morphological, electromagnetic, tribological, mechanical, piezoelectric, thermal and conductive properties of materials. Moreover, being combined with optical methods, such as Raman spectroscopy and scanning nearfield optical microscopy, SPM studies reveal the decipher of chemical and optical properties mapping.

During current talk we will present the latest achievements in SPM instrumentation and methods as well as review numerous examples of its applications to nanoscale studies of smart and functional materials reported by leading scientific groups worldwide.

9. HYBRID GOLD-SILICON SYSTEMS WITH TUNING OPTICAL PROPERTIES

S. Kutrovskaya^{1,2}, A. Osipov¹, A. Shagurina¹, A. Kucherik¹

¹A.G. and N.G. Stoletov Vladimir State University (VISU), 87 Gorki st., Vladimir, Russia, 600000

²Institute of Natural Sciences, Westlake University, No.18, Shilongshan Road, Cloud Town, Xihu District, Hangzhou, China

E-mail: 11stella@mail.ru

The formation of hybrid silicon-gold NPs as a result of the laser action on a mixed colloidal solution is observed. These hybrid NPs are characterized by the amplification and broadening of the near-field photoluminescence spectra compared to pure silicon NPs. A strong sensitivity of the spectral shape of the emitted light to the intensity of the exciting white light is documented. These results may be used for the realization of functional metasurfaces consisting of randomly distributed resonant NPs. Moreover, as the synthesized NPs emit in red, green and yellow they can be used for fabrication of luminescent color screens.

Introduction

Light scattering by micro- and nano-particles is used in multiple photonic applications, e.g. in nano-antennas. One of the important challenges on a way to optimization of such nano-antennas is constituted by the Ohmic losses that are very high at the optical frequencies in Nobel metals (gold, silver) that are promising due to their plasmonic properties. The optical absorption and high Ohmic losses result is a significant heating that negatively affects the performance of metallic nano-antennas. On the other hand, dielectric and semiconductor nanostructures are usually characterized by much lower losses that makes them suitable candidates for nano-antenna applications, potentially. In particular, it has been theoretically predicted [1] and experimentally demonstrated that silicon nanoparticles of a diameter of 100 and 200 nm possess well-resolved dipole resonances in the visible frequency range [2]. The interplay between electric and magnetic multipole resonances in silicon nanoparticles leads to a number of new effects such as the self-focusing of radiation and suppression of the back scattering. Combining the characteristics of Nobel metal and silicon nanoparticles one can potentially take advantage of the specific optical properties of both of them. In this context, hybrid silicon-metal nanoparticles are especially promising as they allow tailoring of the optical properties, plasmon resonances, electric and magnetic interactions for multiple photonic applications.

The development of fabrication techniques that would enable a high-precision control over the nanoparticle (NP) parameters is very important in this context. The method of laser ablation in a liquid phase [3, 4] offers a possibility to control the average size and shape of the synthesized particles by a proper choice of the irradiation conditions (pulse duration, energy density etc.). Low optical losses in silicon NPs are crucial for their applications in photonics, in particular as building blocks for metamaterials and metasurfaces. For these applications it is also important to be able to engineer the near field emission of silicon NPs. This work is aimed at the experimental demonstration of such tailoring and enhancement of the near field emission of silicon NPs by covering them by small-size golden NPs. Golden shells trigger a strong

nanoantenna effect induced by the Purcell enhancement of radiation that strongly affects the near field emission of silicon.

Here we report on the synthesis of hybrid gold-silicon NPs by laser irradiation of colloidal solutions [5]. The increase of the optical near field magnitude in the emission of the NPs is observed and interpreted in terms of the redistribution of the near-field scattering intensity due to the nanoantenna action by gold nanoparticles. The spontaneous ordering of NPs in the course of their deposition allows for the formation of thin films that may be used for creation of metasurfaces suitable for controllable manipulation of the transmission and reflectivity of light [6,7]. These results pave the way to applications of hybrid gold-silicon NPs in optical integrated circuits combining functions of generation, transmission and detection of optical signals.

This work is supported by RFBR grants 16-32-60067 mol_a_dk, 17-42-330928 r_a.

- [1] Evlyukhin AB, Reinhardt C, Seidel A, Luk'yunchuk BS, Chichkov BN. Optical response features of Si-nanoparticle arrays. *Phys. Rev. B*. 2010; 82 (4): 045404.
- [2] L. Shi, T. U. Tuzer, R. Fenollosa, and F. Meseguer, *Adv. Mater.* 24, 5934 (2012).
- [3] S. Kutrovskaya, S. Arakelian, A. Kucherik, A. Osipov, A. Evlyukhin, A. V. Kavokin The Synthesis of Hybrid Gold- Silicon Nano Particles in a Liquid. *Scientific Reports* | 7: 10284 | DOI:10.1038/s41598-017-09634-y
- [4] S.M. Arakelyan, V.P. Veiko, S.V. Kutrovskaya, A.O. Kucherik, A.V. Osipov, T.A. Vartanyan, T.E. Itina, *J. Nanopart. Res.* 18, 1
- [5] Liu P, Chen H, Wang H, Yan J, Lin Z and Yang G. Fabrication of Si/Au core/shell nanoplasmonic structures with ultrasensitive surface-enhanced raman scattering for monolayer molecule detection. *J. Phys. Chem. C*. 2015; 119(2), 1234-1246.
- [6] Yu, N.; Capasso, F. Flat optics with designer metasurfaces. *Nat. Mater.* 2014, 13, 139–150.
- [7] Antipov AA, Arakelyan SM, Vartanyan TA, Itina TE, Kutrovskaya SV, Kucherik AO et al. Optical properties of nanostructured gold-silver films formed by precipitation of small colloid drops. *OptSpectrosc.* 2015; 119 (1): 119-123.

10. STIMULATED LIGHT SCATTERING BY NANOPARTICLES

A. Masalov

P.N.Lebedev Physical Institute of the Russian Academy of Sciences

Leninsky prospect 53, 119991 Moscow, Russia

masalov@sci.lebedev.ru

Two types of light scattering by particles of subwavelength size will be considered: low-frequency (globular) scattering and concentration scattering. In recent experiments these scattering processes were observed in stimulated regime, where the state of particles was controlled by light power.

The low-frequency light scattering is caused by acoustic vibrations of particles; it is similar to Raman scattering, where instead of molecular vibrations the light propagation is disturbed by acoustic vibration of individual particles in the medium. In the case of particles of subwavelength size (microns and nanometers) frequencies of acoustic vibrations are in the GHz range. Spontaneous regime of low-frequency scattering was observed with quartz spheres [1]. With an increase of the intensity of pump radiation the process of spontaneous scattering proceeds to stimulated regime due to striction effect of light on the mechanical oscillations of the particles [2-4]. Typical thresholds for pulsed excitation intensity are hundreds of MW/cm². This type of stimulated scattering can be used as a source of bi-harmonic radiation with a predetermined frequency difference in the GHz range. Furthermore, the resonant bi-harmonic excitation of acoustic waves can be used for radiation exposure to large biological objects (including their destruction).

Concentration light scattering is caused by inhomogeneity of the spatial distribution of suspended particles, i.e. by fluctuations in concentration. On the frequency scale this scattering contributes to the wing of the Rayleigh line. With an increase of pump intensity the process of spontaneous concentration scattering proceeds to stimulated scattering regime, where the light induces the periodic particle concentration grating through gradient (ponderomotive) force. Stimulated scattering mode has been observed in the water suspension of the latex particles of submicron size at pump radiation power of tens milliwatts [5,6]. The frequency shift of the scattered light – tens of Hz – was observed through temporary variation of the scattered light. The stimulated concentration scattering can distort the data on particle size measured by the method of dynamic light scattering.

- [1] E. Duval, A.Boukenter, and B.Champagnon. Phys. Rev. Lett. 56, 2052 (1986).
- [2] N. Tcherniega, M.Samoylovich, A.Kudryavtseva, et al. Opt. Lett. 35, 300 (2010).
- [3] Burkhanov, L.Chaikov, D.Korobov, et al. J. Russ. Laser Research, 33, 496 (2012).
- [4] N. V.Tcherniega, K.I.Zemskov, V.V.Savranskii, et al. Optics Letters, 38, 824 (2013).
- [5] I.S. Burkhanov, L.L.Chaikov. Proc. SPIE, XI International Conference on Correlation Optics, v.9066, 906610 (2013).
- [6] I.S.Burkhanov, S.V.Krivokhizha, L.L.Chaikov. Optics Commun. 381, 360 (2016).

11. VITREOUS SILICA UPON LASER IRRADIATION: THE VIBRATIONAL MODES TREATMENT AND RAMAN ANALYSIS

N. Shcheblanov¹, M. Povarnitsyn²

¹*Ecole Polytechnique, Route de Saclay, 91128 Palaiseau, France*

nikita.shcheblanov@polytechnique.edu

²*Joint Institute for High Temperatures of RAS, Izhorskaya 13 Bld 2, Moscow, 125412 Russia*

tel. +74954842456, povar@ihed.ras.ru

We perform a simulation of vitreous silica to explore the sensitivity to laser irradiation, and, especially, an irreversible densification is considered [1]. We rely on Raman spectroscopy, and we also present partial and total vibrational densities of states [2]. To reveal the structure of the vibrational spectrum, the characteristics of vibrational modes in different frequency ranges are investigated using a mode-projection approach at different symmetries. We consider the main experimental bands, and relate them to a detailed description of the vibrations. Finally, we compare our Raman and VDOS spectra with experimental measurements. The relevance of the proposed research is due to the need for a quantitative description of the processes of change in the elastoplastic and optical properties of glass objects irradiated by laser beams.

[1] N.S. Shcheblanov, M.E. Povarnitsyn, Bond-breaking mechanism of vitreous silica densification by IR femtosecond laser pulses // *Europhys. Lett.* 114, 26004 (2016).

[2] N.S. Shcheblanov, M.E. Povarnitsyn, K.N. Mishchik, A. Tanguy, Raman spectroscopy of femtosecond multipulse irradiation of vitreous silica: Experiment and simulation // *Phys. Rev. B* 97, 054106 (2018).

12. HIGH-THROUGHPUT ATOMIC FORCE MICROSCOPY AND ITS APPLICATIONS

Y. Bobrov, P. Vinar, V. Atepalikhin, S. Leesment, V. Bykov, V. Polyakov

*NT-MDT Spectrum Instruments, Proezd 4922, 4/3 Zelenograd, Moscow, Russian Federation
polyakov@ntmdt-si.com*

Since the introduction of atomic force microscopy (AFM), the issue of the productivity of the method has always been a challenge for AFM community. The term “high-throughput AFM” is usually referred to industrial level instruments mostly connected with applications in semiconductor industry.

Our work is focused on increasing of productivity of AFM instruments for both scientific and industrial needs. The following points are essential for improvement of the throughput of modern AFM:

- Increase of scan speed in most common AFM modes;
- Increase of the general level of automation and robustness of the instrument (i.e. motorization, automation of optical beam deflection sensor alignment, insulation of the instrument from external noise sources, etc.);
- Automation of AFM experiment, i.e. the automation of adjustment of scanning parameters.

Numerous approaches to fast scan (high-speed) AFM have been demonstrated previously by different groups. The common drawbacks of known fast scan solutions are the reduction of available field of view compared to regular AFM and loosening the quality of acquired data that in most practical cases limits the application of high-speed AFM just to the relatively flat samples.

Our Rapid Scan (RS) technology is based on the newly developed piezo-scanner compatible with commercial AFMs of NTegra product line. Improved mechanical resonance properties of RS scanner along with digital damping of its resonances allow to achieve scan rates of up to 10 Hz (at 1000 points per line) with 100×100 μm closed-loop scan range having the same data quality compared to regular scan rates.

Despite there are tens of AFM modes now developed, the tapping mode is still the most widely used one. At the same time, up to the moment, reliable solution for automated adjustment of tapping mode parameters (feedback gain, scan speed, amplitude of the cantilever oscillation) for obtaining relevant data has never been proposed.

We have recently developed Scan Tronic technology that is based on the combination of machine-learning techniques and linear control theory. This approach allows to automate the adjustment of optimal tapping mode scanning parameters for widest range of different samples.

During the talk we will present the physical principles of Rapid Scan and Scan Tronic technologies along with numerous examples of its applications.

13. THE REORIENTATION MECHANISM AND OPTICAL PROPERTIES OF HELIX-FREE FERROELECTRIC LIQUID CRYSTALS

I. Kompanets

*P.N. Lebedev Physical Institute, 53 Leninsky pr., Moscow 119991 Russia
tel. +7 903-124-3235, e-mail kompan@sci.lebedev.ru*

The frame rate of a display is one of the most important parameter of the screen material. To avoid flickering and blurring of images, the frame rate was raised from 25 to 60 Hz and then to 90 Hz, which already meets the medical requirements for the eyes. However, three-dimensional technologies require double the speed, about 180-200 Hz, otherwise watching 3D images is not comfortable, and buyers refuse from 3D TV. The Field Sequential Color technology makes it possible to get brighter and uniform (unstructured) color images and reduce the number of display elements by a factor of three (!). However, it requires three times more frame rates, that is, 270-300 Hz. Thus, in a 3D display using the FSC technology we need a frame rate $100 \text{ Hz} \times 3 \times 2 = 600 \text{ Hz}$ (!).

Modern liquid crystal displays use LC of nematic type (NLC), for which the maximum frame rate is 120-160 Hz only. At the same time, it is known that ferroelectric liquid crystals (FLC) of smectic type possess a sub millisecond electro-optical response. Problems limiting FLC application were solving gradually, and last researches at the P.N. Lebedev Physical Institute of RAS showed that the new specially designed helix-free FLC are the most promising for future applications [1]. These materials distinguish with a rather low value of the spontaneous polarization (less than $50 \text{ nC} / \text{cm}^2$), have rather wide viscosity interval (from 0.3 to 1.0 Poise), and in such FLC in the absence of an electric field there is a periodic spatial deformation of smectic layers with a period of $1.5 \dots 6 \mu\text{m}$.

Below results of studying the helix-free FLC are presented. Notice here that any electro-optical FLC cell is a product of nanotechnology since a thickness of basic layers is in nano-region, namely: 80-100 nm for transparent electrodes, about 60 nm for a dielectric layer, and 20-50 nm for a polymer-orienting layer. The thickness of smectic layers is a few nm as well.

The process of FLC main optical axis (director) reorientation under the action of an alternating electric field depends on which of the two dissipative coefficients – rotational or shear viscosity predominates. When an electric field of the frequency f acts on the FLC, and $\tau_m \cdot f \ll 1$ in comparison with the Maxwellian relaxation time τ_m [2], then the FLC behaves as a liquid with a rotation viscosity. On the contrary, at sufficiently high frequencies ($\tau_m \cdot f \gg 1$), the FLC behaves as an amorphous solid, and its dissipative coefficient is the shear viscosity. Director reorientation in studied FLC is due to the motion of solitons – spatially localized waves of a stationary profile moving along smectic layers. They arise in an alternating electric field upon transition to the Maxwellian mechanism of energy dissipation. Experimental results and a proposed theoretical model confirm the presence of FLC spatial-periodic deformation and such a mechanism of FLC director reorientation.

The frequency and field dependences of the optical response time in FLC experimental cells were studied experimentally for modulation of light transmission, scattering and phase delay with a high rate. It was shown that a periodical deformation of smectic layers is responsible for optical properties of novel FLCs. Really, fast electro-optical response with

continuous gray scale in a transparent mode, which could be used in display devices, is observed in FLC compositions with rather long deformation period, more than 3 μm . Intensive light scattering in FLC, which could be used in polarized-free devices is manifested in compositions with rather short deformation period, of 1.5 \div 2.0 μm . FLC compositions with a deformation period of about 3 μm are more preferable for fast changing the phase delay (initiated by light scattering switching ON) with arising the spatially inhomogeneous phase structure, which could be used for suppressing an ability of a laser beam to the interference and speckle-noise formation.

The new FLC materials provided unique parameters of light modulation unattainable for FLC analogs. In a bistable light-scattering mode, a state with intensive scattering can be turned ON and OFF for a few tens of microseconds and memorized for the time exceeding the switching time up to six orders of magnitude (for several tens of seconds) or until a pulse of opposite polarity appears.

In a transparent mode, in an electric field of the order of 1 V / μm (at the control voltage of \pm 1.5 V) the experimental samples of electro-optical cells show a modulation characteristic with the fastest optical response (about 25 microseconds) and the highest modulation frequency (up to 7 kHz), including hysteresis-free characteristic with a continuous gray scale up to 6 kHz. The explanation of such a limit frequency is discussed.

Possible applications of these research results are in the fast LC displays and video projectors, especially based on FLCOS (FLC on silicon), 3D and FSC technologies, in polarizer-free optical shutters and modulators (including IR ones), in screens of electronic books and 3D visualizers of volumetric displays, in electro-optical despecklers suppressing speckles in laser images etc.

[1] Andreev, T. Andreeva, I. Kompanets, N. Zalyapin, H. Xu, M. Pivnenko and D. Chu, Fast bistable intensive light scattering in helix-free ferroelectric liquid crystals, *Applied Optics*, 55, 3483 (2016).

[2] L. D. Landau and E. M. Lifshits, *Theory of Elasticity* (Moscow, Publishing House "Nauka"), p. 188 (1987).

14. ELECTROMAGNETIC PROPERTIES OF POLYMER MWCNT-BASED COMPOSITES WITH ALUMINOSILICATE HOLLOW MICROSPHERES

D. Meisak^{1,2}, D. Bychanok¹, G. Gorokhov¹, J. Macutkevic², J. Banys² and P. Kuzhir¹

¹*Research Institute for Nuclear Problems BSU, Bobruiskaya st. 11, 220030 Minsk*

²*Vilnius University, Physics faculty, Saulėtekio st. 9, LT-10222 Vilnius*

e-mail: dariameysak@gmail.com

Multiwall carbon nanotubes (MWCNT) are very useful and promising material for the production of polymer composites with controlled electromagnetic properties [1]. The filler content, type of dispersion and polymer matrix are most important parameters defining the electromagnetic response of composites in the frequency range up to THz. Varying of these parameters allows obtaining materials both above and below percolation threshold, which is very important for practical applications related to the producing of effective microwave absorbers [2-3]. Addition aluminosilicate hollow microspheres (ASHS) to the polymer matrix during the preparation of composites offers an additional possibility for varying electromagnetic response of composite and simultaneously leads to decrease the density of the material, which is crucial for aerospace applications.

In the present work, we consider epoxy/MWCNT/ASHS composites and investigate the effect of ASHS inclusions on the effective dielectric permittivity of the composite. The composites with various MWCNT content were prepared by standard technology [1] and the spheres (in amount up to 30% wt.) were added at the final stage after dispersing the nanotubes in the polymer matrix before curing.

The electromagnetic properties of obtained materials were experimentally investigated in frequency ranges 20 Hz- 2 MHz, 12-18 GHz, and 0.1-1 THz. The samples under study demonstrate good absorption ability of electromagnetic radiation. The addition of ASHS allows achieving a controlled decrease of dielectric permittivity of the composite. Also, the applicability of the Bruggeman's effective medium model [4] was checked in wide frequency range and used for a theoretical description of the composite dielectric permittivity spectra.

- [1] D. Bychanok et al, Prog. Electromagn. Res. M, **53**, 9-16 (2017)
- [2] S. V. Kondrashov et al, Polymer Science D, **10**, №3, 279-284 (2017)
- [3] D. Bychanok et. al, Phys. Stat. Solid. B, **255**, №1, 1700224 (2017)
- [4] D.A.G. Bruggeman, Annalen der physik, **416**, №7, 636-664 (1935)

15. LASER SPECTROSCOPY METHODS FOR MEASURING OF LUMINESCENCE KINETICS

A. Povolotskiy

Institute of Chemistry, Saint-Petersburg State University, Saint-Petersburg, Russia
alexey.povolotskiy@spbu.ru

Information about the energy and lifetime of excited electronic states plays an important role in modern scientific research. These data are necessary both to determine the physical, chemical, and functional properties of new phosphors (including doped rare-earth ions), and to determine the mechanisms of physical and chemical processes that pass through excited electronic states. Such processes include photoluminescence, concentration quenching of luminescence, charge transfer, energy transfer, chemical reactions etc. In the study of luminescent properties, data on the kinetics of luminescence are of particular interest. The part of the kinetic curve corresponding to the increase in luminescence allows to determine the pumping path of the excited electron state. The luminescence decay is used to calculate the observed lifetime of the excited electronic state (Fig. 1).

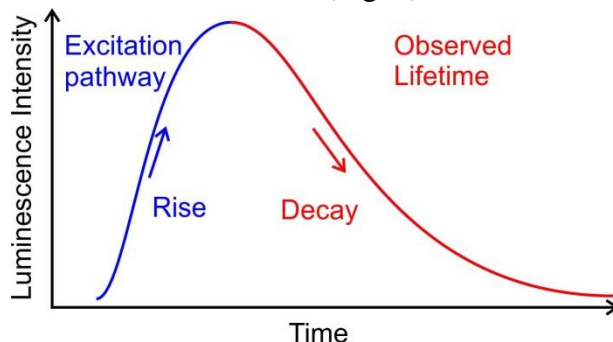

Fig. 1 Rise and decay of the photoluminescence curve can be used for investigation of the excitation pathway and observed lifetime respectively.

The pumping of the excited electron state and the time of the radiative transition can lie in the time range from hundreds of femtoseconds to several seconds, depending on the nature of the luminescent centers and their environment. Depending on the time range, various methods are used to measure the kinetic curves of luminescence. Investigation of the luminescence spectra kinetics can be realized with laser methods: nanosecond laser spectroscopy and ultrafast fluorescence up-conversion technique. The talk is devoted to the description of modern laser spectroscopy methods and experimental setups for measuring of luminescence kinetics.

This work was supported by the Russian Foundation for Basic Research grant # 18-29-12106.

16. FIBER BASED QUANTUM CRYPTOGRAPHY WITH POLARIZATION STATES.

A. Duplinskiy^{1,3}, E. Kiktenko^{1,2}, V. Kurochkin¹, A. Fedorov¹, Y. Kurochkin¹

¹Russian Quantum Center, Skolkovo, Moscow 143025, Russia

²Steklov Mathematical Institute of Russian Academy of Sciences, Moscow 119991, Russia

³Moscow Institute of Physics and Technology, Dolgoprudny, Moscow Region, 141700, Russia

In this work, we report an implementation of quantum-secured data transmission in the infrastructure of Sberbank of Russia in standard communication lines in Moscow

The experiment is realized on the basis of the already deployed urban fiber-optic communication channels with significant losses. We realize the decoy-state BB84 QKD protocol using the one-way scheme with polarization encoding for generating keys. Quantum-generated keys are then used for continuous key renewal in the hardware devices for establishing a quantum-secured VPN Tunnel between Sberbank. The used hybrid approach opens possibilities and it is promising for integrating into the already existing information security infrastructure.

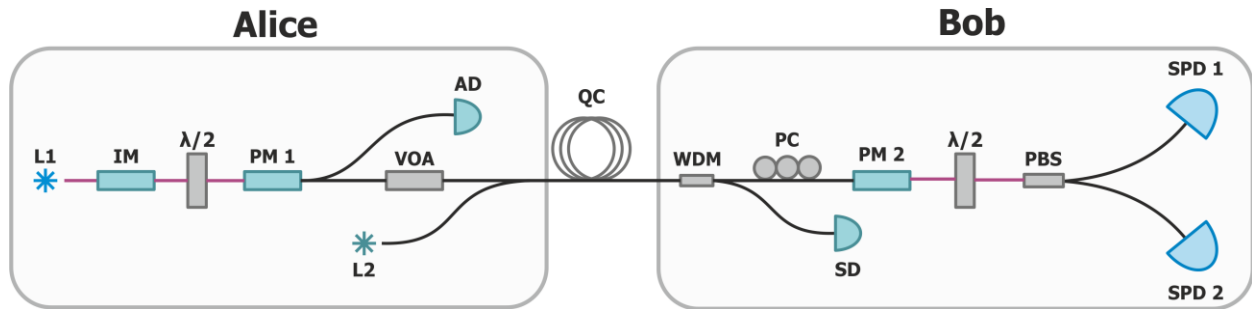

Figure 1. The setup for the generation of quantum keys using the polarization-encoding scheme is presented, where L1 is the light source, IM is the intensity modulator, $\lambda/2$ is the half-wave plate, PM1 and PM2 are phase modulators, VOA is the variable optical attenuator, L2 is the synchronization laser, SD is the synchronization detector, WDM is the wavelength-division multiplexing filter, PC is the polarization controller, AD is the monitoring detector, QC is the quantum channel (urban fiber channel), PBS is the polarization beamsplitter, and SPD1 and SPD2 are single-photon detectors. Purple lines indicate the polarization-maintaining fiber.

Due to significant losses in the urban fiber-optic communication lines, we use the recently suggested one-way scheme of key distribution with fast polarization encoding. The setup is based on LiNbO₃ phase modulators, single laser source for states generation, and two single-photon detectors (Fig. 1).

An important improvement in compare with recent experiments on realizing three-node QKD network in Moscow is the inclusion of an intensity modulator to the optical scheme as well as updating control units and post-processing software for the implementation of the decoy-state QKD protocol. Quantum-generated keys then used for continuous key renewal in the hardware devices for establishing quantum-secured VPN Tunnel by Amicon.

The used fibre-optic communication lines are deployed between the Sberbank office on Bol'shaya Andron'yevskaya street (Alice) and the Sberbank office on Vavilova street (Bob): the one is used for QKD and another one for information transmitting

17. CARBON NANOCOMPOSITES FOR 3D-PRINTING APPLICATIONS

G. Gorokhov¹, D. Bychanok¹, D. Meisak¹, I. Shlyk¹, A. Liubimau²,
P. Angelova³, E. Ivanov³, R. Kotsilkova³, M. Casa⁴, P. Ciambelli⁴
and P. Kuzhir¹

¹Research Institute for Nuclear Problems, 220030 Babruiskaya str. 11, Minsk, Belarus

²Belarusian State Technological University, Minsk, Belarus

³OLEM, Institute of Mechanics Bulgarian Academy of Sciences, Acad. G. Bonchev str. 4,
Sofia, 1113, Bulgaria

⁴Narrando srl., Fisciano, Italy

glebgorokhov@yandex.ru

Additive technologies are of great interest for solving different problems in science and industry[1]. One of the most widely used additive technologies is fused deposition modeling (FDM 3D-printing). The range of FDM printing applications can be significantly increased by the use of nanocomposite materials with non-trivial electromagnetic response[2]. Carbon-based polymer nanocomposites can be useful as 3D-printable materials due to their relatively low filler content and the possibility to be produced and applied with conventional methods.

The electromagnetic properties of composites based on thermoplastic polymers and filled with different concentrations of graphene nanoplatelets (GNP), multiwall carbon nanotubes (MWCNT) and their mixtures were investigated in the microwave frequency region. It was shown that investigated fillers affect the composite electromagnetic response in different ways: nanotubes affect both parts of dielectric permittivity, whilst graphene nanoplatelets impact mainly the real part of the permittivity. It can be used for tailoring the electromagnetic properties of a composite[3].

The synergy between MWCNT and GNP fillers was observed in form of the dielectric permittivity value increase. Such an effect can be useful for the minimization of total filler content making the composites more economically valuable and less viscous. The viscosity level is of great importance for the FDM 3D-printing stability.

Acknowledgements: this work is supported by H2020 RISE 734164 Graphene 3D project.

[1] Paddubskaya *et al.*, “Electromagnetic and thermal properties of three-dimensional printed multilayered nano-carbon/poly(lactic) acid structures,” *J. Appl. Phys.*, vol. 119, no. 13, p. 135102, Apr. 2016.

[2] L. Egiziano *et al.*, “Morphological, rheological and electrical study of PLA reinforced with carbon-based fillers for 3D printing applications,” presented at the 9TH INTERNATIONAL CONFERENCE ON “TIMES OF POLYMERS AND COMPOSITES”: From Aerospace to Nanotechnology, Ischia, Italy, 2018, p. 020152.

[3] D. Micheli, A. Vricella, R. Pastore, and M. Marchetti, “Synthesis and electromagnetic characterization of frequency selective radar absorbing materials using carbon nanopowders,” *Carbon*, vol. 77, pp. 756–774, Oct. 2014.

**18. OPTICAL SPIN ORIENTATION OF ELECTRONS AND NUCLEI IN
SEMICONDUCTORS CONTROLLED
BY SHOCKLEY–READ–HALL RECOMBINATION**

V. Kalevich

¹*Ioffe Institute, St. Petersburg, Russia*

²*Spin Optics Laboratory, Saint Petersburg State University, St. Petersburg, Russia
tel.: 7-812-2927140, e-mail: kalevich@solid.ioffe.ru*

This presentation is a review of the recent experimental and theoretical studies of the effect of spin-dependent Shockley-Read-Hall recombination via deep paramagnetic centers on optical spin orientation of electrons and nuclei in semiconductors and semiconductor nanostructures. Presently, such investigations attract a great interest since the spin-dependent recombination can provide at room temperature an abnormally high (up to 100%) spin polarization of free conduction-band electrons, electrons bound at paramagnetic centers and intrinsic nuclei of the centers in zero and weak magnetic fields [1-9].

These phenomena are illustrated by experiments performed at room temperature on Ga(In)AsN nitride alloys ([N] ~ 1%) and their quantum wells. Optical pumping and polarized photoluminescence were used to create and measure spin polarization of free electrons.

Hyperfine interaction of spin-polarized bound electron with the intrinsic nucleus of the paramagnetic center is discussed in details since it exerts considerable influence on the electron polarization being an origin for a strong electron spin relaxation and dynamic nuclear polarization. In particular, electron-nuclear spin beats induced by hyperfine coupling of bound electron with the defect nucleus in zero external magnetic field have been predicted and observed [10].

The developed kinetic theory of both continuous-wave and pulsed optical spin orientation and of spin-dependent recombination in a semiconductor in the magnetic field describes qualitatively the main experimental findings.

- [1] V.K. Kalevich, E.L. Ivchenko, M.M. Afanasiev et al., JETP Lett. **82**, 455 (2005).
- [2] V.K. Kalevich, E.L. Ivchenko, A.Yu. Shiryaev et al., JETP Lett. **85**, 174 (2007).
- [3] X.J. Wang, I.A. Buyanova, F. Zhao et al., Nat. Mater. **8**, 198 (2009).
- [4] E.L. Ivchenko, V.K. Kalevich, A.Yu. Shiryaev et al., J. Phys.: Condens. Matter **22**, 465804 (2010).
- [5] V.K. Kalevich, M.M. Afanasiev, A.Yu. Shiryaev, and A.Yu. Egorov. Phys. Rev. B **85**, 035205 (2012).
- [6] Y. Puttisong, X.J. Wang, I.A. Buyanova et al., Nat. Commun. **4**, 1751 (2013).
- [7] E.L. Ivchenko, L.A. Bakaleinikov, and V.K. Kalevich. Phys. Rev. B **91**, 205202 (2015).
- [8] E.L. Ivchenko, L.A. Bakaleinikov, M.M. Afanasiev, V.K. Kalevich. Phys. Solid State **58**, 1539 (2016).
- [9] [V.G. Ibarra-Sierra](#), [J.C. Sandoval-Santana](#), [S. Azaizia](#) et al., Phys. Rev. B **95**, 195204 (2017).
- [10] S. Azaizia, H. Carrère, J.C. Sandoval-Santana et al., Phys. Rev. B **97**, 155201 (2018).

19. DIRECTED AND HIGHLY POLARIZED SPASING OF SILVER NANOPARTICLES FROM BENEATH THE THIN AMPLIFYING FILM

A. Kamaliev, N. Toropov, T. Vartanyan

*ITMO University, Kronverkskiy pr. 49, St. Petersburg 197101, Russian Federation
+7(911)2895606, Tigran.Vartanyan@mail.ru*

Since the seminal work of D.J. Bergman and M.I. Stockman [1] several groups have contributed to the theoretical description of the proposed subwavelength laser termed spaser as well as to its experimental realization. In accord with the basic idea, spasers differ from ordinary lasers only in the resonator realization sharing with them the necessity of inverted amplifying media. Instead of the resonators in the form of Fabry-Perot cavities used in common lasers, spasers use localized plasmon resonances in metal nanoparticles. Collective oscillations of free electrons against positive background in a metal nanoparticle modify the photonic states density in its vicinity enabling stimulated emission on selected frequencies. Already realized spasers are based on different experimental techniques that provides for the spectral and geometrical coupling between the laser dye and plasmonic nanoparticles. In this contribution we describe a new scheme that features directed and highly polarized stimulated emission from plasmonic nanoparticles.

The experimental setup is like given in [2]. A monolayer of silver nanoparticles was prepared via physical vapor deposition and subsequent dewetting on a quartz substrate. The obtained monolayer of silver nanoparticles was covered with a spacer layer made of PMMA followed by Coumarin 481 as a gain medium. The samples were excited by the third harmonic of a Nd:YAG laser at normal incidence. The pulse duration was 10 ns, while the beam diameter was 7 mm. When the energy of the laser pulses at the wavelength of 355 nm exceeds 2 mJ a new narrow emission line pops up over the broad fluorescence band. Contrary to the behavior of the broad fluorescence band that starts to saturate at this level of excitation, the narrow emission line intensity continues to grow linearly with the energy of excitation pulses in the whole exploded interval up to 9 mJ. The rate of the linear growth after the threshold is 1.5 times larger than below threshold. The spectral width of the narrow line is only 10 nm, much smaller than the FWHM of the broad fluorescent band that is equal to 64 nm. The narrow emission line is fully polarized in the scattering plane, while the broad fluorescence band is unpolarized. The narrow emission line intensity reaches a sharp maximum at the scattering angle of 45°.

Thus, the experimental evidence of directed and highly polarized spasing of silver nanoparticles from beneath the thin amplifying film has been obtained for the first time.

[1] Bergman, D.J. and Stockman, M.I., "Surface Plasmon Amplification by Stimulated Emission of Radiation: Quantum Generation of Coherent Surface Plasmons in Nanosystems," *Phys. Rev. Lett.* **90**, 027402 (2003)

[2] Kamaliev A.N., Toropov N.A., Vartanyan T.A. Spasers monolayer based on silver nanoparticles // *Proceedings of SPIE*, **10672**, 1067224 (2018).

20. SITE-SELECTIVE SPECTROSCOPY OF QUANTUM-DOT-DOPED NANOCOMPOSITES

K. Karimullin, A. Arzhanov, K. Magaryan, A. Naumov

Institute for Spectroscopy RAS, Dept. of Solid State Spectroscopy, Lab. of Electronic Spectra of Molecules, 5 Fizicheskaya Str., 108840, Moscow, Troitsk, Russia

Moscow State Pedagogical University, Institute of Physics, Technology and Information Systems, E.V. Shpol'skii Chair of Theoretical Physics, 29 Malaya Pirogovskaya Str., 119991 Moscow, Russia

tel.: +7(916)556-09-37, e-mail: kamil@isan.troitsk.ru

Among the various areas of modern materials science, actively developing and promising is the creation of composite structures in which the properties of semiconductor nanocrystals and the material of a solid matrix are combined. Nanocomposites are widely used in various fields of science and technology. On the basis of materials with semiconductor colloidal quantum dots, efficient and economical light-emitting devices, luminescent coatings and labels, and spectral devices are produced [1]. Among the urgent problems can be identified a search for new active media for laser generation, sources of nonclassical light for quantum optics and computer science, elements for photovoltaic devices and nanoelectronics. Fluorescent labels and sensors based on semiconductor quantum dots are extremely in demand in biology, medicine and various diagnostic methods [2].

We study two types of quantum-dot-doped nanocomposites. The first are the thin films of self-assembled colloidal quantum dots spreaded on a glass plate. We used double-coated colloidal CdSe/CdS/ZnS quantum dots (QD-light, Russia), dissolved in high concentration in toluene to prepare the samples. Declared variation of size of quantum dots was 3 – 7 nm. Spin coating technique wasn't used because of the large loss of the QD-solution during the creation of sample with sufficient optical density. An arrangement and procedure to spread quantum dots on a glass substrate have been developed to prepare the samples [3]. Additional measurements were performed by means of luminescence microspectroscopy to clarify the optical quality and spectral properties of the samples [4]. We obtain ultrafast optical dephasing in a wide range of cryogenic temperatures (4.5 – 50 K) in an ensemble of CdSe/CdS/ZnS quantum dots [5] with relaxation times about 1 ps. Unlike impurity molecules of organic dyes, for which the optical dephasing times at cryogenic temperatures are of the order of a few nanoseconds, in the case of the quantum dots, there is an ultrafast relaxation dynamics (with characteristic times of hundreds of femtoseconds). Possible reasons for such fast processes can be related to the inhomogeneity of the structure of the quantum dots themselves, to the features of the internal dynamics of the emitting core (e.g., with the blinking effect), and also to the surface states on the shells. In addition, the dispersion in size and the strongly inhomogeneous local environment can lead to ultrafast relaxation in the ensemble of quantum dots.

Further, we studied the second type of samples with quantum dots synthesized inside of a liquid crystal matrix. Nanocomposites were fabricated in the liquid crystal phase using template-controlled synthesis [6]. Liquid crystalline mesophase is used as a reactor for the synthesis and stabilization of semiconductor QDs. CdSe QDs synthesized in the metal alkanoates (for our samples the cadmium octanoate CdC₈ was used) at various temperatures

(180 °C and 220 °C) have different sizes [7]. With temperature decrease to the ambient the ionic thermotropic liquid state of CdC₈ crystallizes. That leads to the formation of the anisotropic glass that holds the layered smectic-A structure with quantum dots grown inside. We investigated the luminescence properties of such nanocomposites with 1.8 nm and 2.3 nm CdSe QDs. Luminescence spectra of the samples were measured by means of confocal luminescence microscope. The use of an additional visualization scheme allows one to investigate the dependence of luminescence spectra on the structural features of the sample [8]. We measured and analyzed at T = 77 – 300 K the temperature dependence of the excitonic luminescence spectrum of our samples. Analysis within the framework of a theoretical model that takes into account the electron-phonon interaction inside quantum dots made it possible to calculate the values of the Huang-Rice factor and the average phonon energy in the nanocrystals under study [9].

The work is partially supported by the Russian Science Foundation (#14-12-01415 – manufacturing of a thin films of quantum dots; study of temperature dependencies of QD-doped structures) and the Russian Foundation for Basic Research (# 18-02-01121 – photon-echo spectroscopy of nanocomposites). K.K., A.A. and K.M. acknowledge the grant of the President of the Russian Federation (# MK-342.2017.2 – spectroscopy studies of a new luminescent materials based on quantum dots).

- [1] J. Bao, M.G. Bawendi, *Nature*. – 2015. – V. 523. – P. 67.
- [2] E. Cai, P. Ge, S.H. Lee et al., *Angewandte Chemie Int. Ed.* – 2014. – V. 53, No 46. – P. 12484.
- [3] K.R. Karimullin, M.V. Knyazev, A.I. Arzhanov, L.A. Nurtdinova, A.V. Naumov, *J. Phys. Conf. Ser.* – 2017. – V. 859. – Art. No 012010.
- [4] K.R. Karimullin, A.I. Arzhanov, A.V. Naumov, *Bull. RAS Phys.* – 2017. – V. 81, No 12. – P. 1396.
- [5] A.I. Arzhanov, K.R. Karimullin, A.V. Naumov, *Bull. Lebedev Phys. Inst.* – 2018. – V. 45, No 3. – P. 91.
- [6] T.A. Mirnaya, V.N. Asaula, S.V. Volkov, A.S. Tolochko, D.A. Melnik, G.V. Klimusheva, *Phys. Chem. Solid State.* – 2012. – V. 13. – P. 131.
- [7] A. Lyashchova, A. Dmytruk, I. Dmitruk, G. Klimusheva, T. Mirnaya and V. Asaula, *Nanoscale Res. Lett.* 9 (2014) 88.
- [8] K.A. Magarian, V.V. Fedyanin, K.R. Karimullin, I.A. Vasilieva, G.V. Klimusheva, *J. Phys.: Conf. Ser.* – 2013. – V. 478. – Art. No 012007.
- [9] K.A. Magaryan, K.R. Karimullin, I.A. Vasilieva, A.V. Naumov, *Optics and Spectroscopy.* – 2019. – V. 126, No 1 (in press).

21. СПЕКТРАЛЬНЫЕ СВОЙСТВА ЛАЗЕРНЫХ ПЛАНАРНЫХ ВОЛНОВОДОВ НА ОСНОВЕ ФТОРИДНЫХ КЕРАМИК И ТВЕРДЫХ РАСТВОРОВ

А. Федин¹, С. Сергеев²

¹) ВлГУ, г. Владимир

²) БГТУ «ВОЕНМЕХ» им. Д.Ф. Устинова, г. Санкт-Петербург

тел. +7 (4922) 33-52-42

e-mail a_fedin@list.ru

Появление в последнее десятилетие мощных лазерных диодов для накачки твердотельных лазерных сред, расширение их спектрального диапазона повысило интерес к созданию и исследованию новых типов планарных оптических волноводов. Активные лазерные среды в форме планарных волноводов обладают рядом преимуществ по сравнению с объемными лазерными средами. Такие достоинства планарных волноводов как большая длина взаимодействия излучения со средой, сохранение линейной поляризации лазерного излучения, компактность представляют значительный интерес для фотоники.

В настоящей работе исследованы спектральные характеристики созданных методом горячего формования фторидных керамических и кристаллических смешанных оптических планарных волноводов типа $Me_1F_2 - Me_2F_3$ с разностью показателей преломления между активной средой (сердцевинной) и отражающей оболочкой не более $10^{-2}-10^{-4}$. Фторидные лазерные материалы обладают широким спектральным окном прозрачности – от УФ (~ 0.2 мкм) до ИК (~ 11 мкм) области спектра, и могут быть активированы редкоземельными ионами с высокой концентрацией (до 10^{21} см⁻³) без существенного тушения люминесценции.

На примере планарного волновода с сердцевинной из смешанных кристаллов неодимфлюорита $CaF_2-NdF_3:Nd^{3+}$ (длина 55 мм, ширина 5 мм, высота 1.3 мм) с двойной отражающей оболочкой из LiF для повышения эффективности возбуждения волновода показано, что лазерные материалы на основе фторидов обладают рядом существенных преимуществ по сравнению с оксидными материалами, особенно при создании широкодиапазонных усилителей. При мощной боковой накачке волноводов матрицами лазерных диодов с длиной волны вблизи 0.8 мкм и мощностью более 1 кВт обнаружена люминесценция как на одной длине волны, так и на двух длинах волн одновременно (вблизи 0.9 и 1.05 мкм), что позволяет управлять их спектроскопическими свойствами. При этом фториды имеют более узкий, по сравнению с оксидами, фононный спектр, что существенно снижает вероятность потерь на многофононную безызлучательную

релаксацию. Причем меньшие линейный и нелинейный показатели преломления снижают вероятность различных нелинейных процессов при высокой интенсивности распространяющегося излучения. Это позволяет повышать эффективность генерации, что способствует расширению возможностей фотонных технологий. Также обсуждены перспективы дальнейших исследований.

22. NANOSCALE ARCHITECTONICS OF NATURAL GRAPHENE-LIKE CARBON

*N. Rozhkova¹, A. Kovalchuk^{1,2}, S. Rozhkov¹, A. Kucherik³,
A. Prihodko²*

¹*Institute of Geology Karelian Research Center RAS, Petrozavodsk, Russia*

²*Peter the Great St. Petersburg Polytechnic University, St. Petersburg, Russia*

³*Vladimir State University, Vladimir, Russia*

Tel: +7814 2780189, e-mail: rozhkova@krc.karelia.ru

The most attractive properties of carbon materials are associated with the ability to form new nanoscale architectonic forms. Recently, one- and two-dimensional carbon layers including graphene and nanoribbons, became a subject of study as promising materials for electronics, spintronics and medicine [1].

New approaches to the synthesis of nanostructures and the ability to effect on their electronic, chemical, mechanical and magnetic properties by controlling the parameters of defects are developing [2]. A positive role of defects reflects in initiating the creation of new materials and compounds namely for nanoscale structures. Therefore, the study of shungite carbon (ShC) as a new graphene-like material and its structural modifications is of scientific and practical interest [3].

Clustering of non-planar graphenes of ShC is a key process of a multilevel structural organization scenario and of structural transformations in systems of various physico-chemical nature. ShC favorably differs from all synthetic objects by fixed lateral dimensions (~ 1 nm) and amphiphilicity of graphene fragments. Water contributes into the formation of structural hierarchy of ShC, and, in general, fractal structure and porosity of bulk ShC. The reverse process of releasing of graphene fragments was realized through preparation of stable aqueous dispersions of ShC nanoparticles [4]. Such processing and further condensation of the dispersion guarantee reproducibility of structural peculiarities of basic element and its clustering at all levels up to 3D-net formation. The three structural levels of nanoparticles (stacks, globules and nets) can be governed by the polarity or condensation conditions of dispersions. Spatially arranged fractals of bended, curved, mono- or stacked graphene layers that provide new properties were reported for specially treated ShC powder [5].

Graphene motive in ShC nanoparticles was enhanced in thin films produced by sublimation of ShC powder in vacuum. Anomaly of the conductivity of films in the temperature range 80-120 K was reported [6].

Paper reports on ShC nanoparticles in films produced from stable dispersions after laser beam treatment of nano- and femto- durations that show similar structural organization and conductivity.

[1] Zhang J, Terrones M, Park CR, et al. Carbon 2016, 98. P. 708-732.

[2] Ziatdinov AM, Skrylnik PG, Saenko NS: Phys. Chem. Chem. Phys. 2017, 19. P. 26957-26968.

- [3] Rozhkova NN, Rozhkov SP, Goryunov AS: In Carbon Nanomaterials Sourcebook K.D. Sattler, Ed. CRC Press, 2016, V 1. P. 151-174.
- [4] Sheka EF, Rozhkova NN, Int. J. Smart Nano Mater. 2016, N 5. P. 1-16.
- [5] Chou NH., Pierce N., Leic Y., et al. Carbon. – 2018. N 130. - P. 105-111.
- [6] Kovalchuk AA, Prihodko AV. St. Petersburg Polytechnic University Jour.: Physics and Mathematics. 2018. N3, (in Press)

23. LASER TECHNOLOGY FOR LOW DIMENSIONAL NANOCLUSTER PHYSICS

*S. Arakelian, I. Chestnov, A. Kucherik,
C. Kutrovskaya, A. Istratov, T. Khudaiberganov*

*Department of Physics and Applied Mathematics, Vladimir State University,
Gorky Str. 87, 600000 Vladimir, Russia, arak@vlsu.ru*

1. We studied in both theory and experiment the laser-induced nanocluster structures of different types (in topology and element composition) taking into account the correlations in nanoparticle ensemble by quantum states. The problem of high temperature superconductivity due to topological surface structures with correlated states (resulting in coupled states for charged particles on new dimensional principles) are under our consideration.

We applied several laser procedures to obtain the nanostructures and thin films with controllable topology. Namely, in addition to the direct laser modification of solid surfaces, we used, first, the laser ablation of targets in liquid to obtain colloidal systems and, second, to deposit the nanoparticles from the colloid on a solid surface for formation of nanostructures in necessary way by two technique: the laser radiation action and the droplet falling from the nozzle drop jet [1,2]. In [3] the several existing experiment opportunities to fabricate the topology different structures are presented.

In experiment, we have seen competition between increase conductivity while opening new channels in a spatially inhomogeneous charged structure and increase the resistance by increasing of the areas between the conductive grains. Such electrical transport properties (due to quantum correlated states resulting in tunnel and hopping electroconductivity) may be presented as a special type of topological electrophysical surface structures (both localized and delocalized coupled states for charged carriers). Dramatic enhancement of electroconductivity (in several orders) has been observed in our experiments due to variation of topological peculiarities of a nanocluster thin film system (cf. [4]).

2. The physical properties of nanocluster systems are very sensitive to the form, size and distance between their composing elements. The fact is very well known for any material in general, but to change these parameters and to carry out the stable conditions for ordinary solid state object we need both to put the object under extremal high pressure ($\gtrsim 10^6$ atm) and to work in low (liquid He) temperature range ($\lesssim 30$ K) [5].

In contrast, the nanocluster structures can be easily modified in both necessary direction and by controllable way in the femto- nanophotonics experiments. The variation of the enumerated above topology parameters can result in new type of correlation states for charged particles. Moreover, the electronic energetic bands of the materials can vary dramatically in the case, resulting in new physical behavior of the system, in particular, in optical response.

In superconductor problem the question usually is how to fabricate the coupling states (around the forbidden band) at high (usually nitrogen) temperature ($\gtrsim 140$ K) for charged particles being responsible for electroconductivity. In particular, the superconductivity enhancement mechanism does work due to temporary change of atom positions, e.g. for $\text{YBa}_2\text{Cu}_3\text{O}_6/\text{YBCO}$ – under IR-laser radiation (X-ray is preferable) – cf. [6]. In this aspect

deformation of crystallic lattice (under 10^7 atm) has been used as a detector of superhigh pressure [7]. But it is a non-equilibrium process in principle.

As to equilibrium state we discuss some alternative mechanisms of electron coupling for cluster system as well (not via standard phonon coupling [5]).

3. We consider, in present paper, the physical principles of dramatic increase of the electroconductivity in complexes with different element composition for thin multilayered cluster films when the free charged particles are propagating along the conductive surface. We have not interesting the principal parameters for superconductivity, i.e. critical current value (up to several hundred Amperes as usually), strength of the effect, behavior in magnetic fields at room temperature, etc. But we discuss the possible mechanisms responsible for high electroconductivity and features of obtaining the hopping conductivity in such laser-induced inhomogeneous thin film with surface structures up to 100 nm thickness. The approach is reasonable because there is a fundamental problem of the critical current density drop with an increase in the coating thickness (more than several microns) for superconducting layers, and it is impossible to obtain the single-layer films with high critical current on different substrates [8]. Principal fact is that in thin film/granular structure the Meissner effect, being traditionally verification for a superconductivity, doesn't work [5], and an abrupt increase in electrical conductivity depending on the topology of a nanostructured film surface has been experimentally observed by us [4].

4. The main new items of our study are based on several principal effects.

First, to study the bulk and surface conductivity contributions controllable in large range by a deposited cluster topology.

In the cluster shape-stability conception it may be presented as well in analogy with nucleus stability in geometrical approach. Surface equation for cluster as a function of shape can be presented in the form:

$$r(\vartheta) = R (1 + \alpha_0 + \alpha_2 P_2(\cos\vartheta) + \alpha_3 P_3(\cos\vartheta) + \dots), \quad (1)$$

where $r(\vartheta)$ – radius-vector for nanoobject, R – spherical cluster radius, α_i – small parameters of shape-deformation from spherical shape ($i=0,2,3$), P_i – Legendre polynomial. When α_0, α_2 – small, $\alpha_i = 0$ for $i > 2$, and we have the cluster volume V in linear approximation vs α_0 : $V = \frac{4}{3}\pi R^3 (1 + 3\alpha_0 + \frac{3}{5}\alpha_2^2)$. In spherical approximation we have $\alpha_0 = -\frac{1}{5}\alpha_2^2$. For incompressible cluster should be $V = \text{const} (= \frac{4}{3}\pi R^3)$ in such topological model. Several topological structures for nanoobject, obtained by computer simulation, are presented by us for some selected cases. From the very beginning the shape of the body was spherical (radius R) which is perturbed by variation of some key parameters. The modification of the cluster shape, changes, as well, the energetic electronic levels in frame of shell model, and optical spectra vary with different optical response.

Our computer simulation procedure results in good coincidence with our experimental results for both electroresistance and optical spectra.

For a superconductor such processes (ordering and changes under the effect of e.g. an external magnetic field) are related to the behavior of the electron subsystem. But in standard bulk sample (in contrast to the situation in an inhomogeneous medium) the state of electron subsystem is different: the ordering is determined by the state of the lattice while the electrical transport properties are associated with the redistribution of electrons. The main question then

is whether there is an interaction between the lattice and the electron subsystem or they are independent. For a cluster system the answer to the first statement should be positive. Thus, the size quantization (shell structure is namely extreme case of size quantization) results in effective increase of the density states value, and consequently the critical temperature T_c increases as well (cf. [5]).

Second, to analyze the nonlinear dynamic model for superconductivity by different mechanisms. The problem has been formulated in frame of simple but general nonlinear Verhulst model being initially applied to genetic processes in time t [9]:

$$dN/dt = (\alpha - N + \gamma N)(1 - N), \quad (2)$$

where N – density number of the Cooper pairs; α – some numerical parameter for concrete process; γ – parameter of their arise which shows the difference between two processes, i.e. appearance and disappearance of the pairs for $\gamma \neq 0$. The case occurs when there is an asymmetry in average state of the system. Last term $\sim (-\gamma N^2)$ indicates a natural limitation of the charge concentration determined by different reasons in each physical system with saturation.

When $\gamma < 0$ we have not a coupling pair, and for a steady state solution $N_0 = 0$. But for critical quantity $\gamma = 0$ the state $N_0 = 0$ becomes unstable, and new branch in solution arises: we have a bifurcation and transition to the steady state $N_0 = \gamma$ (second order phase transition).

Moreover, there is a critical value of fluctuations in the system σ_c ; when for $\sigma^2 > \sigma_c^2$ the splitting of the thermodynamic free energy density $W(N)$ in two peaks (bimodal state) takes place. This can interpretate as a spontaneous breaking of symmetry being a principal effect for the problem of superconductivity. The case means that noise induces the transition in the system being stable in determinate conditions. In our case the noise means that the variations of topological parameters occur.

In frame of physical picture, because for superconductivity the pairing of electrons (the (e-e)-Cooper pair) is necessary, the question is how this effect, being a phase transition, occurs for initially independent and/or diffusion/random electrons propagating in the medium under external electric field. It is a general problem for phase transition induced by the noise. The optical spectra are modified in the case, as well. They should determine the efficiency of necessary pairing under condition when the coupling energy for electrons is more than energy gap in the density distribution of energetic levels for electron in nanoclusters.

Third, to consider a quantum mobility of electrons over different trajectories in a spatially inhomogeneous structures/nanocluster system. The multiple trajectories for charged carriers/electrons in inhomogeneous cluster structure may be presented in general fundamental approach based on quantum statistical physics, including analogy with the path integral theory [10]. For sequence (in time t) of spatial position (over x -coordinate) of electrons the conditions are: $x(0) = 0, a_1 < x(t_1) > b_1, \dots, a_n < x(t_n) > b_n$, where $(a_i - b_i)$ – i -section along $x(t)$, $0 < t_1 < t_2 < \dots < t_n$. Typical trajectories for quantum particle can be presented by following scheme: $F[x(t)] \rightarrow F(\dots, x_i, x_{i+1} \dots)$. For small time interval Δt , where $\Delta t = \varepsilon$, and $t_{i+1} = t_i + \varepsilon$, we can present $x(t) \approx x_i \equiv x(t_i)$ and have an ordinary function with the functional parameter $\langle (\frac{x_{k+1} - x_k}{\varepsilon})^2 \rangle \sim \frac{1}{\varepsilon}$. For $\varepsilon \rightarrow 0$ we have infinite velocity of the electron drift, but although the quantum trajectories are chaotic and fractal type (for $\varepsilon \rightarrow 0$) we can obtain,

nevertheless, a finite drift velocity for electrons due to averaging over some reasonable on practice both time interval and spatial section.

5. We carried out some computer simulation to obtain the optical spectra transmission for different topological nanostructures. The results are in good agreement with our experimental data for the (Au+Ag)-nanostructure thin film.

6. Obtained results give us an opportunity to establish the basis of new physical principles to create the functional elements for optoelectronics and photonics in hybrid set-up (optics + electrophysics) by the different topology controllable nanoclusters with dramatic increase of both electroconductivity and optical response vs spatial structure of nanoclusters in thin films at room temperature.

This work is supported by RFBR grants 16-42-330461 r_a

- [1] Kavokin A. V., Kutrovsкая S. V., et. al. The crossover between tunnel and hopping conductivity in granulated films of noble metals. *Superlattices and Microstructures* V. 111, Nov. 2017, P. 335-339.
- [2] Kutrovsкая S. V. , Arakelian S. M., et. al. The Synthesis of Hybrid Gold- Silicon Nano Particles in a Liquid. *Scientific Reports* 7: 10284, 6 pp., 2017.
- [3] Arakelian S.M., Kucherik A.O., Prokoshev V.G., et al., Introduction to the femtosecond nanophotonics, Fundamental principles and methods of laser diagnostics and control of nanostructured materials., M.: Logos, Ed. Prof. S. Arakelian, 2015, 744 P.
- [4] Arakelian S., Kucherik A., et. al. Verification of the quantum dimension effects in electrical conductivity with different topology of laser-induced thin-film structures. *Journal of Physics: Conference Series*. 2018. V.951. Article number 012018 (1-5).
- [5] Lifshitz E.M., Pitaevsky L.P. *Theoretical Physics. Statistical Physics. Part.2: Theory of Condensate State.* Vol. IX. M.: Fizmatlit, 5 Ed, 2015, 440P.
- [6] Brent A. Howe. *Crystal Structure and Superconductivity of YBa₂Cu₃O_{7-x}*, Thesis. Minnesota State University, Mankato, Minnesota, 2014.
- [7] Li Li, Donald J. Weidner, Juhua Chen, et.al. X-ray strain analysis at high pressure: Effect of plastic deformation in MnO. *J. of Appl. Physics*, V. 95, No. 12, p. 8357-8365, 2004.
- [8] Lee S.H., Lee H., Lee J.W., at al. RCE-DR, a novel process for coated conductor fabrication with performance. *Superconductor Science and Technology*, V. 27, № 4, p 044018, 2014.
- [9] Horsthemke W., Malek Mansour M. The Influence of External Noise on Non-Equilibrium Phase Transitions. – *Zs. Phys. B* 24, 307-313, 1976.
- [10] Feinmann R.P., Hibbs A.R. *Quantum Mechanics and Path Integrals.* McGraw – Hill Book Company, N.Y., 1965, 384 P.

24. TRANSIENTS AND STEADY-STATES IN FLUORESCENCE FROM COLLECTIVE ENSEMBLES IN DIELECTRIC HOSTS

M. Gladush^{a,b}, N. Lozing^{a,c}, I. Eremchev^a, A. Naumov^{a,b}

^aInstitute of Spectroscopy RAS, 5 Fizicheskaya Str., Troitsk, Moscow, 108840 Russia

^bMoscow State Pedagogical University, 1/1 M. Pirogovskaya Str., Moscow, 119991 Russia

^cNational Research University Higher School of Economics, 20 Myasnitskaya Str., Moscow, Moscow 101000 Russia

tel.: +7(495) 851-02-36, e-mail: mglad@isan.troitsk.ru

We propose a theoretical description of switching between distinct fluorescence regimes produced by a collective ensemble of emitters in a dielectric matrix. The intensity switching patterns correspond to the experimentally observed spontaneous transitions between one "dim" and several "bright" fluorescence states of an ensemble of color centers in a diamond microcrystal irradiated by a continuous wave laser light. Transitions between the states are characterized by well-readable dynamics of growth and decrease in the intensity of the fluorescent signal on the time-scale of seconds. The theory explaining the observed emission regimes and transition dynamics is based on the possibility for a collective ensemble of emitting centers inside a dielectric microcrystal to show intrinsic optical multistability. It is shown that the material equations describing such a system, in the presence of a considerable inhomogeneity of the ensemble and large values of the phase relaxation rate, retain the possibility of having several stable steady-state solutions that form a multistable optical response for certain combinations of the pump power and concentration of the emitters. Reasonable alternatives for such a behavior are discussed.

This work was supported by the grant of the Russian Foundation for Basic Research (RFBR 16-02-01174).

25. FORMATION OF A COLLECTIVE BOSONIC POLARON IN THE EXCITON POLARITON CONDENSATE

T. Khudaiberganov¹, I. Chestnov^{1,2}, A. Kavokin²

¹Vladimir State University, 600000 Vladimir, Russia

²Institute of Natural Sciences, Westlake University, No. 18, Shilongshan Road, Cloud Town, Xihu District, Hangzhou, China

Bosonic condensation of microcavity polaritons is accompanied by their relaxation from the ensemble of excited states into a single quantum state. The excess of energy is transferred to the crystal lattice [1] that eventually involves heating of the structure (Fig. 1a). Creation of the condensate results in the local increase of the temperature which leads to the red shift of the exciton energy providing the mechanism for polariton self-trapping.

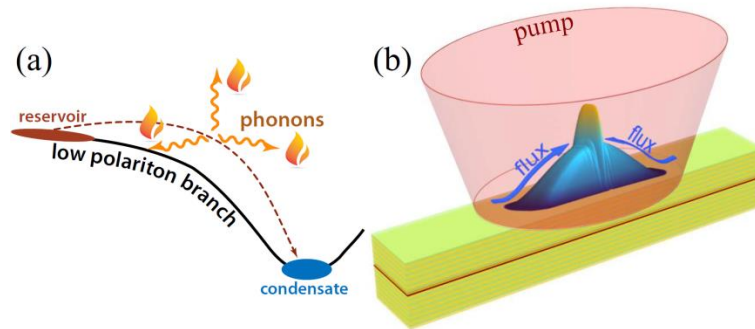

Fig. 1. (a) The schematic showing the dispersion of the low polariton branch and the phonon-assisted scattering processes leading to heating of the crystal lattice. (b) Sketch of a microcavity stripe excited by a non-resonant pump. The polariton solution is formed as the result of interference of the incoming polariton fluxes.

By employing the driven-dissipative Gross-Pitaevskii model we predict a new type of a stable localized solution supported by the thermally-induced self-trapping in a one-dimensional microcavity structure. We demonstrate that if the heating efficiency exceeds the critical level, the effective nonlinear trapping potential is formed. Because of its driving-dissipative nature the polariton condensates supports the persistent currents flowing towards the center of the trap where the condensate acquires the sink-type structure i.e. it is characterized by the presence of converging density currents, Fig. 1b. We examine the spontaneous formation of these states from the white noise under spatially localized pumping and analyze the criteria for their stability. This finding sheds light on the paradoxical self-trapping effect that seems to contradict the superfluid nature of polariton condensates documented previously [2].

This work is supported by RFBR grants 16-32-60102 mol_a_dk

[1] S. Klemmt, E. Durupt, S. Datta, T. Klein, et al., *Phys. Rev. Lett.* **114**, 186403 (2015).

[2] L. Dominici, M. Petrov, M. Matuszewski, D. Ballarini, et al., *Nature comms.* **6**, 8993 (2015).

26. PHOTON ECHO AS A TECHNIQUE FOR DIAGNOSTICS OF LOW-TEMPERATURE DYNAMICS IN DISORDERED SOLIDS AND NANOCOMPOSITES WITH QUANTUM DOTS

K. Karimullin, A. Arzhanov, A. Naumov

*Institute of Spectroscopy RAS, 5 Fizicheskaya Str., Troitsk, Moscow, 108840 Russia
Moscow State Pedagogical University, 1/1 M. Pirogovskaya Str., Moscow, 119991 Russia
tel.: +7(495) 851-02-36, e-mail: naumov@isan.troitsk.ru*

It is well known that the photon echo (PE) technique provides unique opportunities for studying low-temperature dynamics of complexly structured (disordered) solid-state impurity media. It becomes particularly informative for the measurements to be performed in a wide range of temperatures. Knowing the temperature dependences of characteristic temporal relaxation processes makes it possible to reveal parameters of the low-energy elementary excitations. The series of experimental studies carried out at the Institute of Spectroscopy RAS (Russia) and the University of Bayreuth (Germany) in 1990–2000s with the use of the incoherent PE (IPE) and the double-pulse picosecond PE techniques made an immense contribution to obtaining unique data on spectral diffusion and optical dephasing in organic impurity glasses and polymers for the temperatures from mK to dozens of K [1]. These approaches have additional capabilities in a comparative analysis of data on relaxation processes obtained by PE methods with data on the spectra of single impurity molecules and their temporal dynamics at various temperatures [2]. They may require the use of the original methods in statistical analysis of data regarding the widths of zero-phonon spectral lines (ZPL) for a large number of PE measurements. At the same time, up to nowadays some of the results show significant contradictions that cannot be resolved within the existing models.

In this report we provide an overview of the results obtained until recently using such a combined approach. We discuss new experimental approaches and the possibilities of the methods used to study the microscopic nature of low-energy elementary excitations of the tunneling and vibrational type. The newest experimental results are shown to contribute to the studies of ultrafast low-temperature dynamics in an impurity polymer (polyisobutylene with impurity molecules of tetra-tert-butylterrylene) and clarify the relationship of these processes with the broadening of ZPLs of single impurity molecules [2]. It is also shown that the reverse optical dephasing time, measured by the IPE method, corresponds to the smallest ZPL widths of single molecules, which is in complete agreement with the ideas about the hierarchy of relaxation processes in disordered organic solid media at low temperatures.

In the final part of the talk we present the results of the first experiments on the IPE in nanocomposite media with semiconductor colloidal nanocrystals (quantum dots). The problems of sample preparation when working and managing such materials are discussed. It is shown that the IPE technique will allow one to obtain new information about relaxation processes in such media.

This work was supported by the grant of the Russian Foundation for Basic Research (proj. no 18-02-01121 – echo-spectroscopy of quantum-dot-doped nanocomposites) and by the Program of the Presidium of RAS “Actual problems of photonics” (optical spectroscopy of a new luminescent materials).

[1] Yu. G. Vainer, A. V. Naumov, M. Kol'chenko, R. I. Personov // *Phys. Stat. Sol. B*, 241, 3480 (2004).

[2] M. V. Knyazev, K. R. Karimullin, A. V. Naumov // *Phys. Stat. Sol. B*, 11, 1600414 (2017).

27. LASER SYNTHESIS OF THE WO₃ THIN FILMS FOR SOLID-STATE ELECTROCHROMIC CELLS

L. Parshina¹, O. Novodvorsky¹, O. Khramova¹, A. Lotin¹, P. Shchur²

¹ILIT RAS, Branch of the Federal Scientific Research Center «Crystallography and Photonics» of Russian Academy of Sciences, 140700 Shatura, Russia

² Federal State Unitary Enterprise «All-russian scientific research institute of aviation materials» State Research Center of the Russian Federation, 105005 Moscow, Russia

Tel: +79629937590

Mail: ParshinaLiubov@mail.ru

WO₃ films can change its optical characteristics in the wavelength range from the UV region to the long-wave IR region [1]. Therefore they are used in electrochromic indicators, displays, optical modulators, "clever windows" [2]. At the moment an actual task is a creation of solid-state electrochromic cells on the basis of the WO₃ films. For this purpose it is necessary to determine the production conditions of separate layers of the electrochromic cell and also to investigate the change of their properties at the consecutive deposition of the films. The pulse laser deposition (PLD) method in the droplet-free mode owing to the high density of the particles in the erosive plume and the high degree of ionization of the plume allows to deposition of the films with thickness of several nanometers evenly [3]. The high energy of the particles in the erosive plume allows to reduce the crystallization temperature of the films up to room temperature and to provide the production of the layers of the solid-state electrochromic cell on flexible organic substrates.

The aim of the present work was the production of the WO₃ films by PLD method on single-crystal (*c* - sapphire), amorphous (quartz) substrates and on films of the SnO₂:Sb transparent electrode and also studying optical and electric properties of the WO₃ films and their surfaces morphology. The WO₃ films with thickness from 42 to 275 nm were produced at the substrate temperature from 100 to 300 °C and the oxygen pressure in the range of 10⁻² - 10⁻¹ Torr. The dependence of the films properties on the substrate type, the substrate temperature and the oxygen pressure during the deposition was investigated. The influence of the post-growth thermal annealing on the magnitude of optical transmission in the wide spectral range from 200 to 2000 nm and energy gap width of the WO₃ films was investigated. The transmission dependence of the WO₃ films produced at the room temperature of the substrate on the oxygen pressure during the film growth is presented in Fig. 1. The transmittance of the films produced on both types of the substrates increase in the all spectral region at the increase of the oxygen pressure. It was established that the energy gap width of the WO₃ films produced both on quartz and on sapphire substrates at the room temperature changed from 2.9 to 3.3 eV at the increase of the oxygen pressure range from 20 to 60 mTorr during the film deposition. The change of the oxygen pressure during the WO₃ film growth did not influence on its surface roughness.

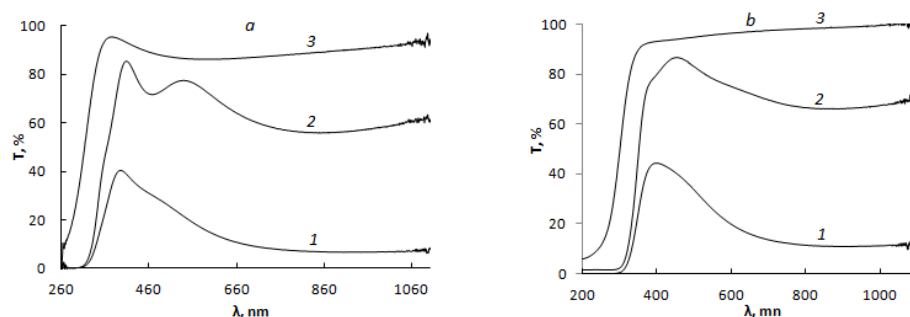

Fig. 1. The transmission of the WO_3 films deposited at the room temperature of the quartz (a) and *c* - sapphire (b) substrates and the oxygen pressure during the film growth: 1 - 20 mTorr, 2 – 40 mTorr, 3 – 60 mTorr.

The transmission change of the thin-film structure at consecutive addition of the layers of the electrochromic composition (*c*- $\text{Al}_2\text{O}_3/\text{SnO}_2:\text{Sb}/\text{WO}_3$) was investigated. The WO_3 layers were deposited at the oxygen pressure of 60 and 40 mTorr. The layers of the electrochromic composition with the WO_3 film produced on the $\text{SnO}_2:\text{Sb}$ transparent electrode at the oxygen pressure of 60 mTorr were subjected to thermal annealing in the oxygen atmosphere at 500 °C within 30 minutes. The transmission of such compositions are presented in Fig. 2.

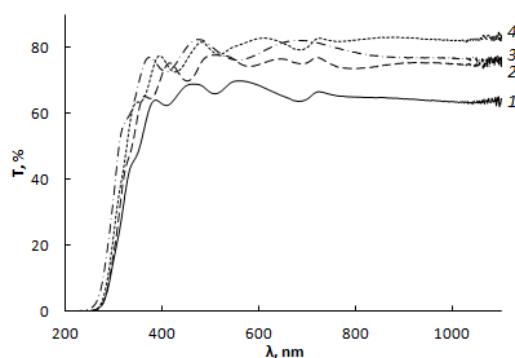

Fig. 2. The transmission change of the thin-film structure at consecutive addition of the layers of the electrochromic composition: $\text{SnO}_2:\text{Sb}$ layer on *c*- Al_2O_3 – 3, WO_3 layer (60 mTorr) on *c*- $\text{Al}_2\text{O}_3/\text{SnO}_2:\text{Sb}$ – 2, WO_3 layer (40 mTorr) on *c*- $\text{Al}_2\text{O}_3/\text{SnO}_2:\text{Sb}$ – 1, WO_3 layer (60 mTorr) on *c*- $\text{Al}_2\text{O}_3/\text{SnO}_2:\text{Sb}$ after thermal annealing in the oxygen atmosphere at 500 °C within 30 minutes – 4.

The optimum oxygen pressure (60 mTorr) during the WO_3 films deposition on the $\text{SnO}_2:\text{Sb}$ transparent thin-film electrodes was determined. It was established that the thermal annealing of the WO_3 films which were grown on the $\text{SnO}_2:\text{Sb}$ films reduced the energy gap width of the WO_3 films from 3.5 to 3.4 eV.

This work was supported by the Federal Agency of Scientific Organizations (Agreement № 007-Г3/Ч3363/26) in part of films production and by the Russian Science Foundation (Project № 16-29-05385, 16-07-00842, 17-07-00615) in part of analysis of films.

- [1] Sauvet K., Sauques L., Rougier A. // *J. Phys. Chem. Solid.*, 2010, Vol. 71. P. 696–699.
- [2] Chiang J.-L., Jan S.-S., Chou J.-C. et al. // *Sens. Actuat. B*, 2011, Vol. 76. P. 624–628.
- [3] Parshina L.S., Khramova O.D., Novodvorsky O.A. et al. // *Semiconductors*, 2017, Vol. 51. № 3, P. 407–411.

28. FORMATION AND TRANSFER OF A TEST-OBJECT IMAGE BY LASER BRIGHTNESS AMPLIFIER WITH OPTICAL BUNCH

A. Galkin, S. Zhirnova, E. Shamanskaya

*Vladimir State University, Vladimir
svetlanna_vik@mail.ru*

The registration of laser-induced processes on the surface of various materials using a laser monitor is presented in many works, for example [1-5]. The problem is that the distance from the processing surface to the input lens of laser monitor is fixed, which is inconvenient in the study of technological processes of laser processing of various materials. The optical bunch allows to carry out researches of processes of interaction of laser radiation with a surface and in cases of rather arbitrary arrangement, both in space, and on remoteness from the laser monitor. The paper presents the results of experiments to obtain an image of a test object using a brightness amplifier and an optical bunch.

As a laser projection microscope, a brightness amplifier on copper vapors CVL-10 was used with the following characteristics: length of the active element $l=0.8$ m, diameter $d=18$ mm, unsaturated gain coefficient $a = 0,14$ cm⁻¹; emitting at a wavelength $\lambda=510.6$ nm. CVL-10 copper vapor laser radiation focuses on the surface of the optical bunch using a lens with a focal length of 125 mm and an antireflection coating of 400 – 700 nm. The paper used a fiber-optic bunch with the following characteristics: the calculated numerical aperture of 0,5; resolution of 8-15 mm⁻¹. An optical wedge (refractive angle $\theta = 4^\circ$) is glued to the end of the optical bunch to reduce the reflection of radiation. After the optical bunch, an optical system consisting of one lens or two lenses was installed to focus the radiation on the test object. Lens material BK7, focal length 50 mm and 200 mm. The model of the treated surface was a test object, which is a plate of polished stainless steel, on which the laser engraving applied strokes with a certain amount per millimeter (from 1.75 to 10 strokes per millimeter).

Images of the surface of the test object at its different location in the experiment were obtained on the screen of a laser projection microscope. When the test object is located at the end of the optical bunch, the periodicity of the structures is observed, but the image contrast is low, since part of the radiation involved in the formation of the image is lost when passing through the optical bunch. When the test object is located in a double focus lens with a focal length of 50 mm, the image of the surface has a low contrast, part of the radiation involved in the construction of the image is lost when passing through the optical bunch and the optical system. When the test object is located after the optical bunch and optical system of two lenses at a distance of 50 mm from the second lens, an image of the surface received in reflected light from the spherical surface of the lens on the screen, which is located behind the test object at a distance of 30 cm, is obtained. Contrast and image clarity is observed.

Images of the test object surface were obtained using a laser projection microscope and an optical bunch. The use of an optical bunch can significantly improve the capabilities of the laser monitor and observe laser technological operations (laser cutting, welding, etc.) at an arbitrary distance from point of impact. In the micro-processing of local areas of 3D-products of complex profile, the use of laser projection monitor together with an optical bunch can give fundamental advantages in the aspect of controllability of the process directly during its implementation and achieve the required/record processing accuracy.

- [1] Zharenova, S.V. Visualization of interaction of laser radiation with a surface of glassy carbon and pirographite by means of the laser monitor / S.V. Zharenova, E.L. Shamanskaya // Third Russian-French Laser Symposium. The thesis's of the reports. St. Petersburg, 22-27 September. – 2008.
- [2] Abramov D.V., Arakelian S.M., Galkin A.F. Melting of carbon heated by concentrated laser radiation in air at atmospheric pressure and at a temperature not exceeding 4000 K (Plavlenie ugleroda, nagrevaemogo skontsentrirrovannym lazernym izlucheniem v vozdukhe pri atmosferom davlenii i temperature, ne prevyshaiushchei 4000 K), Pis'ma v ZhETF, 2006: (84) 315-319 (in Russ).
- [3] Bagaev S.N., Prokoshev V.G., Kucherik A.O., Abramov D.V., Arakelian S.M., Klimovskii I.I. Hydrodynamics of the melt of the metal surface under laser action; Monitoring of real-time mode change (Gidrodinamika rasplava poverkhnosti metalla pri lazernom vozdeistvii; nabludenie smeny rezhimov v real'nom vremeni) Doklady Akademii nauk (DAN), 2004: 395 (2) 83-186 (in Russ).
- [4] Arakelyan S.M., Galkin A.F., Zhirnova S.V., Osipov A.V. Determination of brightness temperature of melting of glassy carbon (Opredelenie yarkostnoi temperatury plavleniya steklougleroda), Journal "Dynamics of complex systems" 2015: (9) 1 (48-50) (in Russ).
- [5] Arakelyan S.M., Galkin A.F., Zhirnova S.V., Shamanskaya E.L. Experimental study of laser-induced processes on the surfaces of carbonaceous materials with simultaneous measuring of their temperatures / Bulletin of the Russian Academy of Sciences. Physics. – 2017. – V.81. – №12. – P.1468-1471.

29. HIGH-POWER X-RAY TUBE FOR MICRO COMPUTER TOMOGRAPHY (MCT)

E. Grachev, E. Kozlov, A. Trubitsyn

*Ryazan State Radio Engineering University, Gagarina 59/1, Ryazan 390005, Russia
tel. +79209725040, e-mail ewg.kozlov2015@yandex.ru*

The current stage of development of X-ray diagnostics methods can be characterized as a stage of symbiosis of modern X-ray technology and digital information technology. The results of such a symbiosis are most pronounced in microfocus fluoroscopy, where so-called microfocus tubes are used as radiation sources. Here you can talk about the emergence of a completely new highly informative tool for the study of the internal structure of opaque objects. In the most positive way, microfocus tubes have proven themselves in X-ray tomography, where the spatial resolution at the level of microns and nanometers is achieved. The corresponding branch of science is called computer microtomography (μ CT) [1]. The unique features of the μ CT made it the “gold standard” of X-ray diagnostics

Advantages of microfocus sources become apparent more distinctly under using of anodes of the transmission type made of thin metal foil in contrast with thick anodes of the reflection type.

Main disadvantage of standard sources of the transmission type is that the upper limit of power dissipating on a standard planar anode of the tube is about 10 W under diameter of the excitatory electron beam spot about 100 μ . Following increase of power leads to melting of the anode material.

The purpose of the work consist in x-ray tube power increasing. The idea to increase power of the microfocus x-ray tube of the transmission type due to application of the heat pipe as an anode [2]. The bottom of the heat pipe is the anode (W) target, and the cap of the heat pipe is the exit (Be) window of anode.

High-temperature heat pipes are often called heat superconductors. Estimates of the magnitude of the power dissipated at the anode are determined as a function of the diameter of the focal spot of the electron beam. Under great thicknesses (>1 mm) of the anode W a value of the dissipated power is determined by heat resistance of tungsten and so substrate does not ensure heat removal from the heating zone. So, in this case ultimate heat power only insignificantly exceeds the power dissipated by the standard composite W-Be anode described in [3]. Tangible benefit in the dissipating power is reached only under very small (<100 μ m) thickness of the anode target. In this case, the thermal resistance of the target becomes small, and the heat locally released at the point of electron beam incidence is dissipated actively by the volume of the high-temperature heat pipe.

Instance, the limiting power dissipated by the 10 μ of tungsten target of the anode “heat pipe” is equal to 100 W for the 100 μ electron beam diameter.

The research has been carried out at expenses of the Russian Science Foundation grant (project No.18-79-10168).

[1] Elliott J.C. and Dover S.D. X-ray microtomography // Journal of Microscopy. – 1982. - 126, 211–213.

[2] Trubitsyn A.A. Transmission type Microfocus X-ray tube with a high level of power dissipated at the anode // Russian Federation Patent No. 2653508 dated 05.10.2018.

[3] Podymskiy A.A. Power X-ray tubes to X-ray imaging (rus.) (PhD Thesis, LETI, S-Petersburg 2016).

30. MODELING THE CLUSTER STRUCTURE OF A BIMETALLIC FRACTAL AG/AU NANOFILM

D. Bukharov, A. Istratov, V. Samyshkin, A. Antipov, O. Novikova, S. Arakelian

Vladimir State University, 87 Gorky, Vladimir, 600000, Russia

Mail: buharovdn@gmail.com

The initial bimetallic fractal films were obtained by laser deposition of metals from solutions [1]. After the laser impact and the formation of clusters on the surface of the substrates, they were studied using the Integra-Aura probe nano-laboratory.

In all cases, in the process of deposition, cluster structures of the dendrite type were formed on the surface of the glass substrate. [1]

To describe the obtained aggregates of the fractal film, the DLA model was chosen [2]. To simulate a cluster, the seed particle was placed in the center of the computational domain. Since there is no interaction between particles in the model, only the interaction of a free particle and a fixed cluster is considered.

In the simulation, the initial concentration and the probability of sticking of particles and aggregation centers were varied within a two-dimensional von Neumann first order neighborhood. [3]

It was found that with a decrease in the value of the probability of sticking in the interval from 1 to 0.01, the generated fractal becomes almost uniformly distributed at the edges (Fig.1.).

On the other hand, the higher the probability of sticking, the more branched a fractal structure forms and the film also becomes more heterogeneous with a dendritic profile, which is confirmed by the values of the fractal dimension.

The proposed approach makes it possible in the first approximation to estimate the effect of the temperature parameter on the character of the resulting structures.

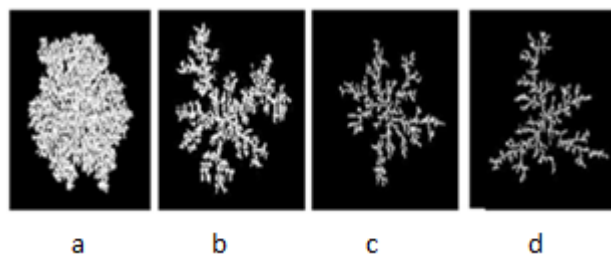

Fig.1. Model images of fractal structures of a film island with a sticking probability: a) 0.01
b) 0.1 c) 0.5 d) 1

This study was supported by the grant of president of Russian Federation by project MK-3053.2017.2.

This study was supported by the Ministry of Science and Higher Education of the Russian Federation (state project no. 3.7530.2017/8.9)

[1] Antipov A.A. et al. Deposition of bimetallic Au / Ag clusters using the method of laser deposition of nanoparticles from colloidal systems / Antipov AA, Arakelyan SM, Kutrovskaya SV, Kucherik AO, Vartanyan T.A. // Optics and Spectroscopy, 2014, t.116. No. 2. P.349-352.

- [2] Menshutin A.Yu., Shchur LN, Multidimensional Generalization of the Diffusion Limited Aggregation Model (DLA) // Mechanics, Management and Computer Science, 2014. 6, 6, №6 (51) C. 110-120
- [3] Kalmykov L.V., Kalmykov V.L., Investigation of individually oriented mechanisms of the dynamics of a single-species population using logical deterministic cellular automata // Computer Research and Modeling, 2015, vol. 7. No. 6. P. 1279-1293.

31. ANTI-COUNTERFEITING FRET BASED INVISIBLE INKS PRELIMINARY INVESTIGATIONS WITH RYLENIC ORGANIC DYES

C. Levi

L.CR. STUDIO – Via Bissuola 40/C – 30173 – Venezia/Mestre
carlo.levi76@gmail.com

Luminescent color tuning can be achieved by varying the chemical structure of a single molecular emitter altering π -conjugation by condensation or functionalization, and by the presence of a second luminescent emitter, tuning the emission characteristics by Fluorescence Resonant Energy Transfer FRET. The applicative range of tailored/coupled fluorescent dyes is wide, spanning from lasing to sensing. Bimolecular FRET mechanism between two organic dyes could increase Photo-Voltaic devices performances in photo-cells coupled with Luminescent Solar Concentrators LSC and in Co-Sensitized Dyes Sensitized Solar Cells DSSC [$\Delta\eta_{PC} \approx 20 \div 80 \%$]. Increase of DSSC Photo-Current is Thickness/Morphology film dependent.

In this preliminary work, emissive RGB triad of commercial BASF-LUMOGEN perilenic-bis-imidic based dyes, developed as LSC and characterized by high QY ($\Phi > 90 \%$) and photostability, are investigated in the FRET donor/acceptor arrangements B/R, B/G and G/R couples for anti-counterfeiting purposes in alcoholic Sol-Gel Ink-Jet Matrix and coated on colorless glass, plastic and adhesive substrates.

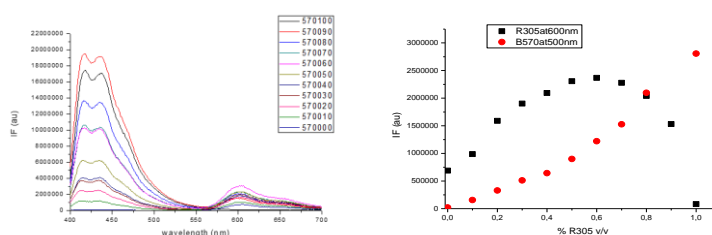

Figure 1: Spectro-fluorimetric analysis of Blue/Red couple spin coated on glass at different molar ratios. Non-linear bell behavior at fixed wavelength of the R305 acceptor show η_{ET}^{max} at B/R 0.4/0.6 molar ratio.

Dye	λ_{max}^{exc} (nm)	λ_{max}^{em} (nm)	D/A _{couple}	η_{ET}^{max}	CIE_{xy}^{em}
B 570	365	450	B/G	50 %	0.23/0.44
G 83	470	510	B/R	57 %	0.43/0.25
R 305	580	595	G/R	67 %	0.48/0.43

Table 1: Solid state photo-physical characteristics of single dyes and donor/acceptor couples.

Future development of Energy Transfer based Inks (ET-INKS) will be selection of synthetic dyes in order to investigate/realize Organic Nanoparticles (ONPs) showing potential Amplified Spontaneous Emission (ASE) behaviour. Dyes nano-aggregation in solution could be achieved by laser ablation and emulsion techniques in order to realize “soft” spherical systems able to surround one or more aggregated dyes. ET-INKS concept could be easily expanded in Organic Optoelectronics (Photovoltaics, Photodetectors and Lasers devices).

[1] S.T. Bailey et al., Optimized Excitation Energy Transfer in Three-Dye Luminescent Solar Concentrator, Solar Energy Materials Solar Cells 91, (2007) 67-75;

- [2] C. Levi, Increasing the DSSC Efficiency via Energy Transfer Mechanism – International Conference on Problems of Strongly Correlated and Interacting Systems, Russian Quantum Center, 28/05 – 31/05 2014, St. Petersburg (RU);
- [3] C. Levi, Implication of FRET in Invisible Inks for Organic Photovoltaic/Security applications. Preliminary Investigations with Organic Dyes - International Conference on New Trends in Quantum/Mesoscopic Physics NTQMP18, Russian-Armenian University, Yerevan (AM), 27/06 – 03/07 2018;
- [4] R. Kumar, S. Lai, Synthesis of Organic Nanoparticles and their Applications in Drug Delivery and Food Nanotechnology, *J. Nanomater Mol. Nanotechnol*, 2014, 3:4;
- [5] A.J.C. Kuehne, M.C. Gather, Organic Lasers: Recent Developments on Materials, Device Geometries and Fabrication Techniques, *Chem. Rev.* 2016, 12823 – 12864.

32. LIGHT EMITTERS FOR HIGH-SPEED OPTOELECTRONIC DIGITAL-TO-ANALOG CONVERSION

A. Bushuev, A. Zolotov, N. Davydov, D. Kochuev, R. Chkalov

Department of Physics and Applied Mathematics,
Vladimir State University, 87 Gorky, Vladimir, 600000, Russia
tel.: +79030601988, e-mail: artem_bushuev_1996@mail.ru

One of the main elements in digital processing systems are digital-to-analog (DAC) and analog-to-digital converters, since the speed and accuracy of the system largely depend on them. The main drawback of parallel-type digital-to-analog converters is the reduction of the system digit capacity while increasing the conversion speed, which makes it necessary to use lower work speeds. The solution of this problem can become the transition from electronic devices to optoelectronic converters, where digital-to-analog conversion will be performed in an optical form and, accordingly, the speed of operation will be inversely proportional to the rise time of the optical signal of optoelectronic emitters.

The simplest implementation of an optoelectronic parallel DAC is a functional diagram presented in Figure 1 [1].

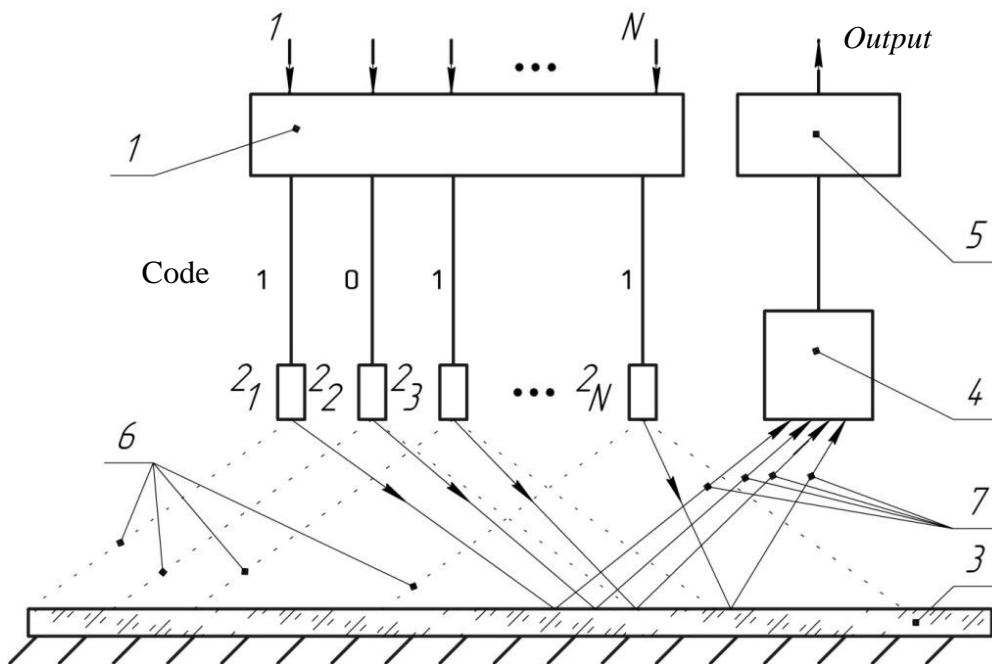

Figure 1. Functional diagram of the operation of an optoelectronic DAC: 1 - current driver; $2_1, 2_2, \dots, 2_N$ - a set of LEDs; 3 - mirror surface; 4 - photodetector; 5 - signal amplifier; 6 - LEDs radiation angle; 7 - light beams incident on the photodetector

With the implementation of such structures, the question of emitting devices of optoelectronic digital-to-analog converters that are capable to operate in the gigahertz range remains unresolved. LEDs and quantum dot-based light emitters at the moment can not provide a sufficiently high working speed due to design features [2]. Developments are underway to create light-emitting transistors that have several advantages over LEDs: high temperature stability (temperature control is not required),

which means there are practically no lattice vibrations; low current consumption (due to the amplifying properties of the transistor); etc.

The paper proposed a new layout of light emitters layers, which is a bipolar light-emitting transistor [3], containing a quantum well between the base and the emitter. The block diagram of the element layers is shown in Figure 2.

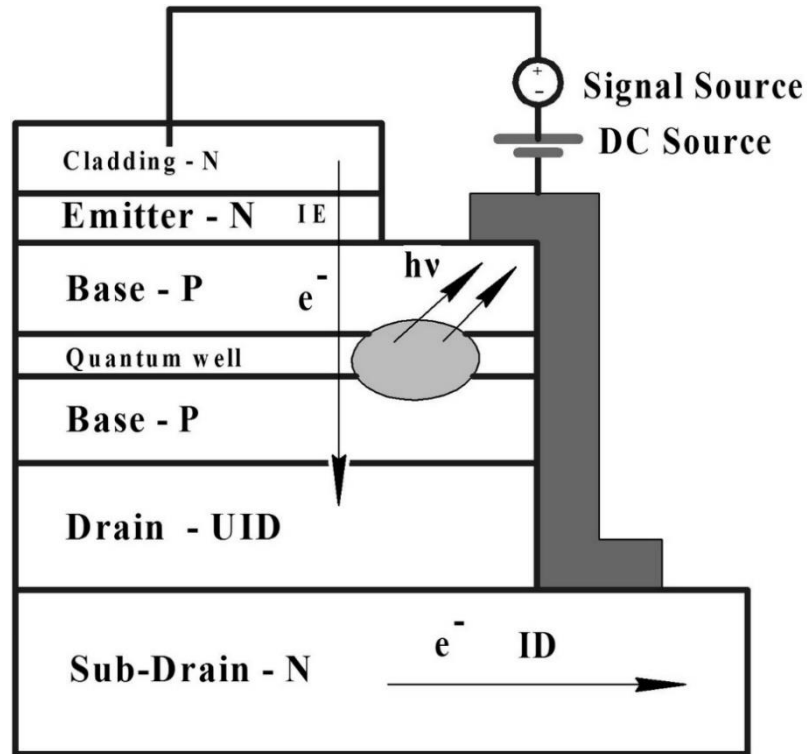

Figure 2. Block diagram of the light-emitting transistor layers

- [1] Zolotov A., Rufitsky M. Cifro-analogovyj preobrazovatel' [Digital-to-analog converter]. Patent RF, no. 2011124564/08, 2012.
- [2] Schubert E. F. Light-emitting diodes. – E. Fred Schubert, 2018.
- [3] Wu C. H. et al. Design and layout of multi Ghz operation of light emitting diodes //Proceedings of the GaAs MAN-TECH Conference. – 2010.

33. SIMULATION OF ELECTRICAL CONDUCTIVITY OF THE BIMETALLIC ISLAND OF THE AG/AU ISLAND NANOFILM

D. Bukharov, A. Istratov, V. Samyshkin, A. Antipov, O. Novikova, S. Arakelian

Vladimir State University, 87 Gorky, Vladimir, 600000, Russia

Mail: buharovdn@gmail.com

The initial bimetallic coatings based on gold and silver nanoparticles were obtained by thermal diffusion deposition of metallic nanoparticles on the surface of a glass substrate [1]. In all cases, cluster structures of the dendrite type, visually similar to DLA clusters, were formed on the surface of the glass substrate during deposition, which determined the choice of the nanofilm island formation model [2].

The current-voltage characteristics were measured using a four-probe circuit with a linear arrangement of contacts [3]. The measured dependence is on average linear (Fig.1).

The conductive properties were modeled in the classical approximation of Ohm's law for a section of a circuit. The resistance for highly branched clusters was calculated using the classical formula, where the magnitude of the conduction path was calculated from the skeleton of the modeled cluster [4], and the ratio of silver and gold particles was chosen to be 50:50.

The simulated volt-ampere characteristics were of the order of 10^{-8} V when the voltage varied from 0.05 to 1 V, which with satisfactory accuracy corresponds to the data of experimental measurements (Fig. 2). A comparison of the electrical conductivity with the islands of silver and gold monometals was also conducted. It was found that the electrical conductivity of the island of bimetal is intermediate in nature and at low voltages up to 0.5 V it tends to the best electrical conductivity of the island of silver.

The proposed approach allows, in the first approximation, to evaluate the conductive properties of the structures obtained.

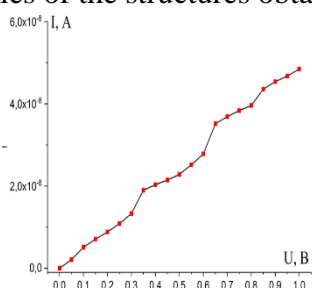

Fig.1. Measured volt ampere characteristics of bimetallic Ag / Au films

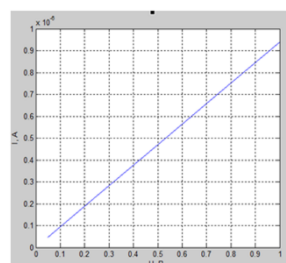

Fig. 2. Simulated volt ampere characteristics

This study was supported by the Ministry of Science and Higher Education of the Russian Federation (state project no. 3.7530.2017/8.9), Russian Foundation for Basic Research grant # 16-42-330461 and by the grant of president of Russian Federation by project MK-3053.2017.2.

[1] Antipov A.A. et al. Deposition of bimetallic Au / Ag clusters using the method of laser deposition of nanoparticles from colloidal systems / Antipov AA, Arakelyan SM, Kutrovskaya SV, Kucherik AO, Vartanyan T.A. // Optics and Spectroscopy, 2014, t.116. No. 2. P.349-352.

[2] Menshutin A.Yu., Shchur LN, Multidimensional Generalization of the Diffusion Limited Aggregation Model (DLA) // Mechanics, Management and Computer Science, 2014. 6, 6, №6 (51) .C. 110-120

- [3] Smits, F.M. Measurement of Sheet Resistivities with the 4-point Probe // Bell System Technical Journal 37, 711–718 (1958).
- [4] Moskalev P.V. Analysis of the structure of a percolation cluster // Journal of Technical Physics, vol. 79, no. 6, 2009.

34. TUNABLE ALEXANDRITE LASER

A. Antipov, A. Putilov

Vladimir State University named after Alexander and Nikolay Stoletovs, 600000, Russia

The use of an alexandrite crystal doped with chromium ions ($\text{BeAl}_2\text{O}_4: \text{Cr}^{3+}$) as an active element makes it possible to obtain a tuning of the radiation wavelength in the range of 720 - 800 nm.

In this work, a pulse-periodic tunable laser with lamp pumping of the active element was designed. The lamp was placed in an elliptical reflector made of doped quartz, which in turn served as a cut-off filter for the ultraviolet pump radiation region. The need for filtering light is due to the degradation of the alexandrite crystal when exposed to UV radiation, and when intensely affected, coloring occurs, resulting in a loss of lasing properties.

A silver coating is applied to the outer side of the reflector, which provides a reflection of pump radiation of $\geq 95\%$ in the absorption spectrum of the alexandrite crystal.

A rod of an alexandrite crystal with a length of 100 mm and a diameter of 6.3 mm was used as an active element. The concentration of Cr^{3+} ions was 0.13 atm.%. The ends of the active element are parallel, with an antireflection coating in the range of 680 - 880 nm $\tau\lambda > 99\%$.

To compensate for the thermal lens arising in an alexandrite crystal during a pumping light pulse, a positive sphere with a focus of 5 meters was used in the reflecting mirror. The translucent mirror is flat with a reflection in the range of 700 - 850 nm $\rho\lambda \sim 75\%$.

To ensure the tuning of the radiation wavelength, a birefringent filter was placed in the laser resonator at an angle to the optical axis. This method of adjustment was chosen because of the low level of non-selective losses and simple control. The birefringent filter is a stack of quartz plates of different thickness.

The optical scheme of the experiment is presented of the figure 1.

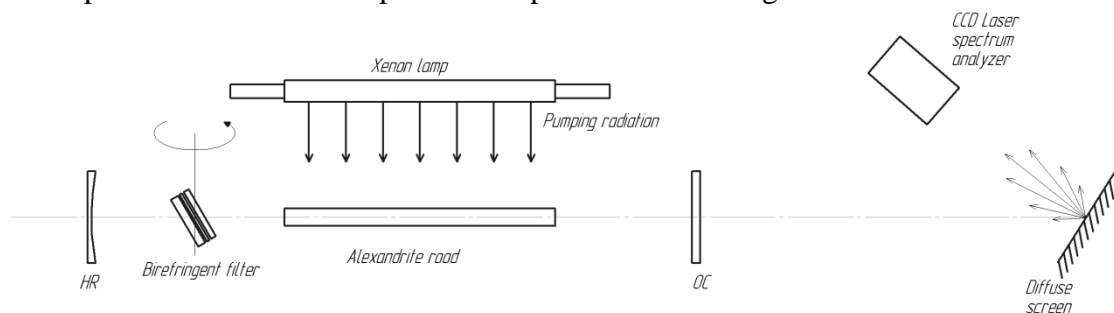

Figure 1. The optical scheme of the experiment to determine the tuning of the emission spectrum

Precise rotation of the foot plates around its axis is accompanied by a violation of the optimal orientation of their axes relative to the plane of incidence of light, as a result of this the shape of the filter's transmission spectrum changes, while the height of the peaks remains approximately constant.

The principle of operation of the birefringent filter allows you to smoothly change the generation spectrum during operation of the laser. At the repetition frequency of the pump pulses from 1 to 15 Hz, a smooth precision rotation of the birefringent filter occurred. The dynamics of the tunable spectrum of laser radiation is presented of the figure 2. For the convenience of perception, an approximation of the amplitudes of the emission spectra was performed. The intensity of the spectrum analyzer was displayed in software in arbitrary units.

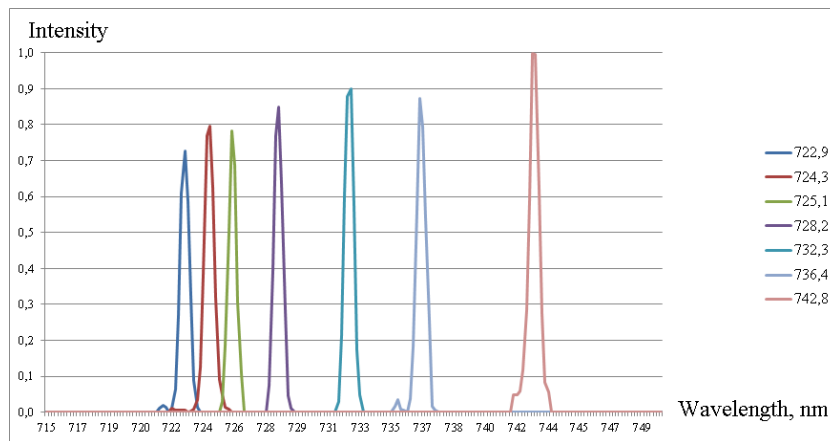

Figure 2. The dependence of the tuning of the laser wavelength on the rotation of the birefringent filter

This method was able to achieve restructuring of the laser emission spectrum of an alexandrite crystal in the range from 722 to 795 nm.

The construction of an emitter on an alexandrite crystal using a birefringent filter, the implementation of Q-switching and frequency doubling makes it possible to create a tunable UV-range laser with a high peak power density and a narrow spectral emission line.

This study was supported by the Ministry of Science and Higher Education of the Russian Federation (state project no. 3.7530.2017/8.9)

- [1] M. J. Damzen, G.M. Thomas, A. Teppitaksak, A. Minassian, Progress in diode-pumped alexandrite lasers as a new resource for future space LIDAR missions // International Conference on Space Optics, Tenerife, Canary Islands, Spain, 7 – 10 october, 2014.
- [2] Е. В. Пестряков, А. И. Алимпиев, В. Н. Матросов, Перспективы развития фемтосекундных лазерных систем на кристаллах бериллиевых алюминатов, активированных ионами хрома и титана // Квантовая электроника, 2001, том 31, номер 8, 689–696.
- [3] И. С. Тырышкина, Н. А. Иванов, В. М. Хулугуров, Узкополосный перестраиваемый лазер на александрите с пассивной модуляцией добротности // Квантовая электроника, 1998, том 25, номер 6, 505–506.

35. LINE-BY-LINE FIBER BRAGG GRATING FABRICATION BY FEMTOSECOND LASER RADIATION

A. Chernikov, K. Khorkov, D. Kochuev, R. Chkalov, V. Prokoshev

Department of Physics and Applied Mathematics,

Vladimir State University named after A. G. and N. G. Stoletovs, 87 Gorky, Vladimir, 600000, Russia

tel.: +79157904262, e-mail: an4ny.che@gmail.com

Fiber Bragg gratings (FBGs) and long-period gratings (LPGs) are one of the most popular optical components have found wide application as sensing elements in sensor devices, as spectral filters in fibre lasers [1, 2], etc. Femtosecond laser technology using to write FBGs in optical fibers without the requirement of material photosensitivity and fabricate optical structures has high thermal stability. The main advantages of the femtosecond writing method is the ability to flexibly change the characteristics [3] of the Bragg grating: the period length and, as a result, the spectral characteristics.

In this work the source of laser radiation was femtosecond Yb:KGW – laser system (wavelength 1029 nm, pulse width 280 fs, pulse repetition rate of 10 kHz, pulse energy 180 μ J at a current of 4 A). As the focusing optics a high numeric aperture microobjective Mitutoyo Plan Apo NIR ($\times 100$, NA = 0.7) was used. FBGs in standard telecommunications single mode fiber Corning SMF-28e⁺ were fabricated without removing the polymer coating. The fiber is mounted on a three-axis translation stage in such a way that the desired FBG can be fabricated by translating the fiber regarding to the focused laser beam [3].

Several FBGs with different characteristics have been made using line-by-line method. For inscription of FBG the following parameters were selected: velocity during exposure to laser radiation $V_1 = 80 \mu\text{m/s}$, velocity without exposure laser radiation $V_2 = 400 \mu\text{m/s}$, pulse energy 150 nJ. Images of inscribed 2nd order (period $\Lambda = 1.05 \mu\text{m}$) and 4th order (period $\Lambda = 2.14 \mu\text{m}$) FBGs is shown in Fig. 1.

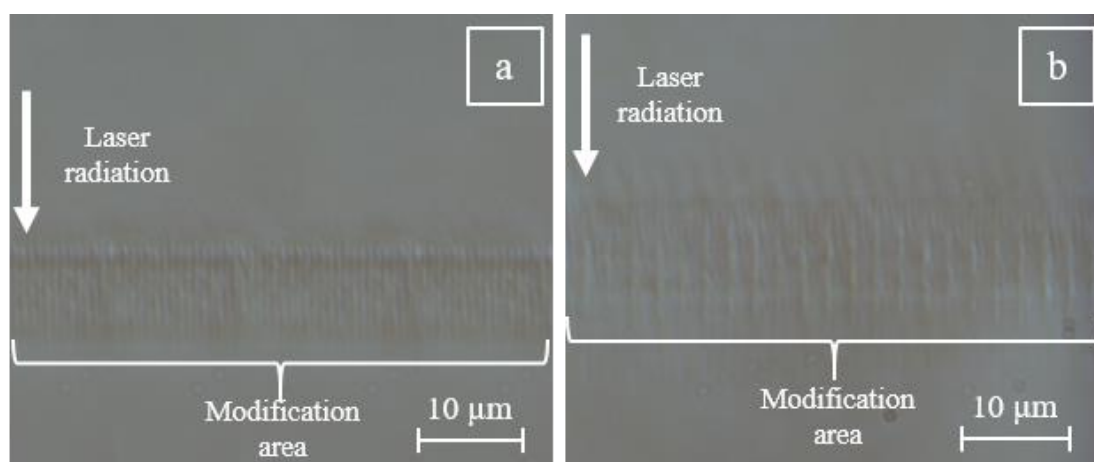

Fig. 1. Images of inscribed FBGs: a – 2nd order FBG; b – 4th order FBG.

In Fig. 1, the modification area completely crosses of the fiber core (8.2 μm) that in turn fulfilled the necessary requirements.

Reflection spectra registration was performed with an optical interrogator module (OSI) NI PXIe-4844. Fig. 2 shows the reflection spectra of fourth order FBGs with a length of 4.28 mm (a) and 6.42 mm (b), period $\Lambda = 2.14 \mu\text{m}$, number of lines $N = 2000$ and 3000.

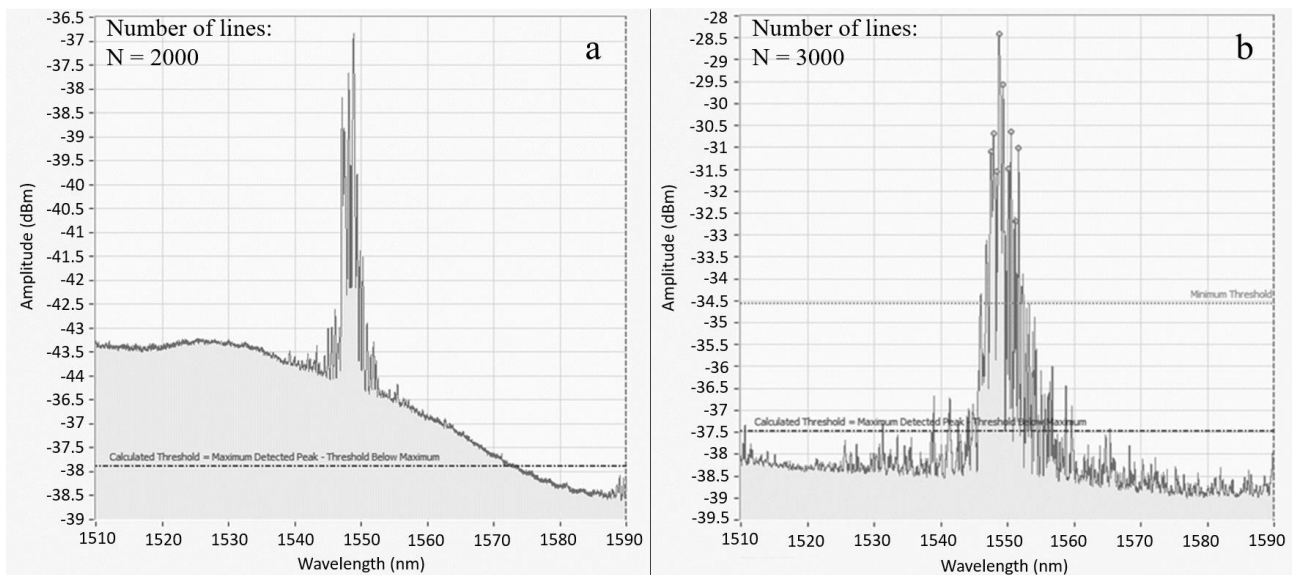

Fig. 2. Reflection spectra of FBGs with different length: a - 4.28 mm; b – 6.42 mm.

With increased of number inscribed lines the reflection amplitude of FBG has increased as shown in Fig. 2 (b). Fig. 2 shows the presence of reflection peaks in the wavelength range 1546-1550 nm, at a previously theoretically calculated central Bragg wavelength at 1550 nm. In each of the reflection spectra there was a set of pronounced peaks, which indicates the heterogeneity of the inscribed FBGs. This in turn can be associated with a number of factors: instability of laser pulses, insufficient uniform translation on the XY axes, and an incorrectly set flatness position of the sample.

The results of inscription of 2nd order and 4th order FBGs in standard telecommunications single mode fiber through the polymer coating using a femtosecond laser radiation are presented.

This work was performed as a part of the state task VLSU 3.5531.2017/8.9 GB-1106/17 and a grant of the RFBR number 16-08-01226.

- [1] Hill K. O. et al. Photosensitivity in optical fiber waveguides: Application to reflection filter fabrication //Applied physics letters. – 1978. – V. 32. – №. 10. – P. 647-649.
- [2] Dostovalov A. V., Wolf A. A., Babin S. A. Long-period fibre grating writing with a slit-apertured femtosecond laser beam ($\lambda= 1026$ nm) //Quantum Electronics. – 2015. – V. 45. – №. 3. – P. 235.
- [3] Chernikov A.S., Khorkov K.S., Kochuev D.A., Chkalov R.V. Modification of the refractive index in an non-photosensitive optical fiber by femtosecond laser radiation // INTERMATIC 2017, International Scientific and Technical Conference. – 2017, V.1, – P. 176-179.

36. THE LASER SYNTHESIS AND DEPOSITION OF GaN NANOPARTICLES

I. Skryabin, V. Samyshkin, A. Osipov, S. Arakelian

Vladimir State University, 87 Gorky, Vladimir, 600000, Russia

Mail: skryabin@vlsu.ru

Modern information systems and different photonics applications require the creation of a new class of materials that allows them to reconstruct their physical properties in a wide range. In particular, quantum computers based on optical calculations need to create new optical logical elements. For using of optical logical elements we have to achieve ultra-fast and broadband transmission and processing of data. In such systems, photons behave as carriers of information, which allow to increase the magnitude in the amount of information transmitted even by narrow-band elements and overcome the delays between connections and minimize the generation of heat associated with conventional embedded electronic circuits.

New promising optoelectronic materials with a wide range of practical applications are structures based on semiconductor nitrides, in particular, gallium nitride. The approach of nanoparticles of gallium nitride is widely used in modern photonics. This material is more convenient than silicon in some respects: it has high thermal, chemical and radiation resistance, high electrical conductivity. Gallium nitride also provides good thermal conductivity, which removes many cooling problems in the working area of the chip.

In this preliminary work, we presented an experimental realization of laser synthesis of semiconductor nanoparticles. In our experiments, a gallium nitride target placed in distilled water and was irradiated by laser. The source of laser irradiation was femtosecond Yb:KGW – laser system (wavelength 1029 nm, pulse width 280 fs, pulse repetition rate of 10 kHz, pulse energy 180 μ J at a current of 4 A). The colloidal solution obtained by the method of laser ablation was studied on a particle size analyzer. As shown in Figure 1, particles with an average size of 144 nm were obtained in the solution.

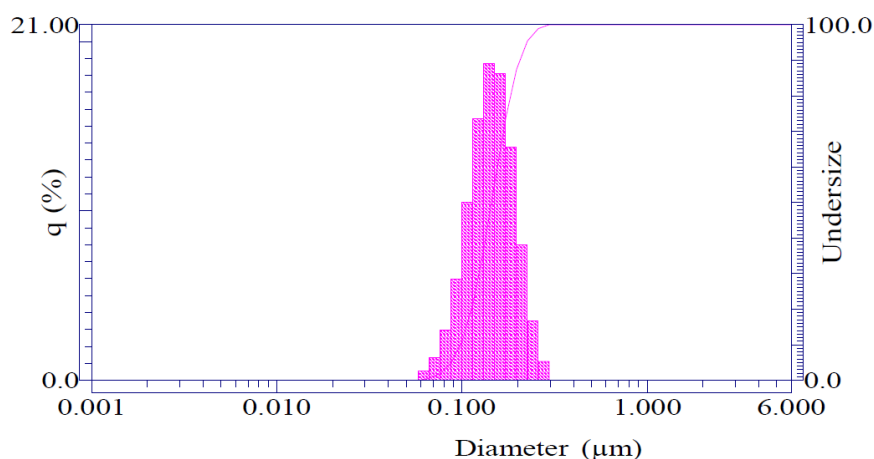

Fig.1. GaN particle size distribution histogram

Further, the obtained particles were deposited on the substrate by the spray-jet method [1], also we have got a Raman spectra of the formed GaN film. The results are consistent with research of GaN films [2]. This confirms the possibility of the obtaining of a two-component semiconductor nanoparticles using laser ablation of a material placed in a liquid.

[1] S. Kutrovskaya, S. Arakelian, A. Kucherik, A. Osipov, A. Evlyukhin, A. V. Kavokin. Scientific Reports | 7: 10284 | DOI:10.1038/s41598-017-09634-y

[2] Z. C. Feng, W. Wang, S. J. Chua, et al. J. Raman Spectrosc. 2001; 32: 840–846

37. INVESTIGATION OF NONLINEAR PROPERTIES OF MATERIALS USING THE Z-SCAN TECHNIQUE AND FEMTOSECOND LASER RADIATION

M. Tarasova, K. Khorkov, D. Kochuev, R. Chkalov, V. Prokoshev

*Department of Physics and Applied Mathematics,
Vladimir State University named after A. G. and N. G. Stoletovs, 87 Gorky, Vladimir,
600000, Russia*

E-mail: trsvmargarita@gmail.com

When using laser radiation, the laws of nonlinear optics play a dominant role. As a result, there is a dependence of the nature of optical phenomena on the magnitude of the light intensity. The dependence of the refractive index of the radiation intensity has the form: $n = n_0 + n_2 I$, where n_0 – the linear part of the refractive index, n_2 – the nonlinear part of the refractive index, I – the radiation intensity.

In this paper, we study the nonlinear-optical properties of thin-film coatings deposited on a quartz glass substrate. The z-scan technique allows not only to determine the value and sign of the nonlinear refractive index n_2 , but also to determine the value of the nonlinear absorption coefficient [1-4]. The technique is based on the effect of self-focusing of laser radiation in a sample that acquires non-linear properties during the passage of laser radiation. The z-scan technique involves moving the sample along the optical axis near the focal plane of the lens, and measuring the power of the radiation transmitted through the sample. Closed-aperture technique is used to determine the nonlinear refractive index, to determine the non-linear absorption coefficient with an open aperture. In Fig. 1 the experimental scheme of z-scan is presented.

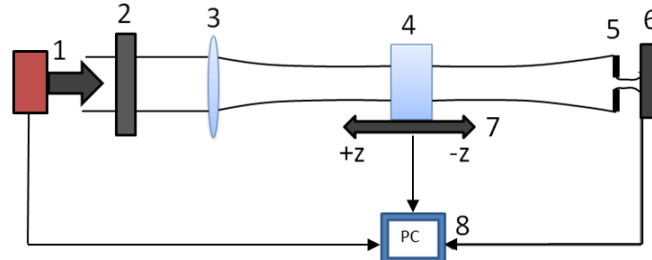

Fig.1. The experimental scheme of z-scan. 1 - laser radiation source, 2 - polarization attenuator, 3 - lens, 4 - sample, 5 - diaphragm, 6 - power meter, 7 - motorized table, 8 - personal computer

A femtosecond laser system with the following parameters was used as a source of laser radiation: a pulse duration of 280 fs, a wavelength of 517 nm, a pulse repetition rate of 10 kHz, the average power varied in the range from 2 to 20 mW. A polarizing attenuator is required for precise adjustment of power values. The sample is located on the motorized table, the algorithm for moving the sample and fixing the readings of the power meter were carried out using a personal computer. When using the open z-scan technique, there is no diaphragm in the experimental scheme. Measurement of nonlinear values by z-scan technique is possible when the laser radiation reaches a certain threshold power value.

As a result of measurements, we obtain graphs of the power of laser radiation transmitted through the sample from the position of the sample. An example of the graphics according to the open z-scan technique is presented in Fig. 2. The calculation of non-linear values is carried out on the basis of the obtained data.

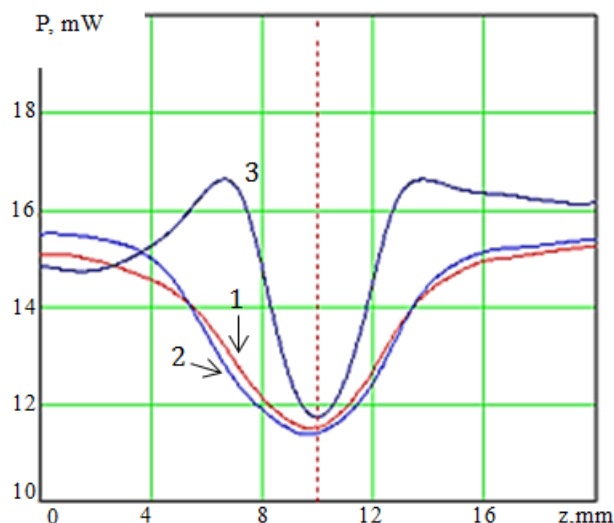

Fig.2. Graph of the transmission of laser radiation through the sample in an experiment with open z-scan. Samples: 1 - applied coating solution; 2 - quartz substrate; 3 - applied thin film coating

Thus, the study of thin-film materials requires high accuracy and repeatability of the measurement iterations. Qualitative measurement results are achievable with the use of automation, recording, which during the experiment exclude the influence of the human factor.

- [1] Sheik-Bahae M., Hutchings D. C., Hagan D. J., Van Stryland E. W. Dispersion of Bound Electronic Nonlinear Refraction in Solids // IEEE Journal of Quantum Electronics , 1991, Vol. 27, No. 5, pp. 1296-1309.
- [2] Kamada K. et al. Two-photon-absorption-induced accumulated thermal effect on femtosecond Z-scan experiments studied with time-resolved thermal-lens spectrometry and its simulation // J. Opt. Soc. Am. B, 2003, Vol. 2, No. 3, pp. 529-536
- [3] Tarasova M. A. Determination of nonlinear refractive index by the method of Z-scanning using femtosecond laser radiation. // Days of science of students of the Vladimir State University named after A. G. and N. G. Stoletov, 2017. P. 423–425
- [4] Tarasova M. A., Khorkov K.S., Kochuev D.A., Prokoshev V.G. Determination of the nonlinear refractive index by the Z-scan method using femtosecond laser radiation // Modern nanotechnologies and nanophotonics for science and industry: proceedings of the 6th Intern. Conf., 2018. P. 141-143.

38. RESEARCH OF THE ABSORPTION OF LASER RADIATION BY POWDER MATERIALS

S. Alexandrov¹, S. Usov², A. Voznesenskaya³, A. Zhdanov³, D. Kochuev³

¹ *Division of Computational Mathematics and Engineering, Institute for Computational Science, Ton Duc Thang University, Ho Chi Minh City, Vietnam and Faculty of Civil Engineering, Ton Duc Thang University, Ho Chi Minh City, Vietnam*

² *"TSZP" Limited Liability Company "TSZP", Moscow, Russia*

³ *Vladimir State University named after A. G. and N. G. Stoletovs, 87 Gorky, Vladimir, 600000, Russia*

tel.: +7-920-913-88-87, e-mail: 2obk@bk.ru

There are a number of problems in the manufacture of parts by the methods of selective laser melting. When laser radiation is applied to low-melting and fine-dispersed components, intense gas formation occurs, which contributes to the formation of pores (due to a complex temperature load on an anisotropic body, cracking is possible). There is also the problem of creating complex alloys with a homogeneous distribution of alloying components [1]. Some powder materials during processing require less energy, leading to melting, so it is reasonable to apply approaches that change their ability to absorb incident laser radiation. The intensity of the absorption of the powder material depends not only on the physicochemical properties of the powder material, but also on its particle size distribution, bulk density of the powder, including the angle of incidence of laser radiation [2]. The radiation passes through the voids between the powder particles and interacts with the underlying particles. The distribution of heat in the depth of the powder layer is determined by the usual mechanism of heat transfer. The intensity of laser radiation decreases with its penetration into the powder layer [3]. To reduce the absorption capacity of the granules of the powder material, it is possible to use larger particles, apply reflective coatings, and also reduce the surface roughness of the granules of the powder composition [4]. A change in the absorption coefficient of laser radiation by particles of powder materials will make it possible to expand the range of alloying additives in metals, the use of which is limited to different melting points of the powder material [5]. In this paper, we consider various approaches to the change in the absorption capacity of granules of powder materials, and also study the absorption properties of various powder materials.

The analysis of the size distribution and morphology of particles of various powder materials was carried out using scanning electron microscopy. Investigation of the efficiency of absorption of laser radiation was carried out using a continuous ytterbium laser on the developed stand. The experiment was carried out according to the following scheme: the defocused laser beam was directed to the surface of powder materials, the laser beam diameter on the surface of the powder material was 8 mm, the temperature was measured using a pyrometer. The measurement was carried out at different power densities of the laser radiation. The range of variation of the laser power was chosen in such a way as to eliminate melting, evaporation, and other changes in the state of aggregation of the powders.

[1] Yan S. J. et al. Investigating aluminum alloy by graphene nanoflakes // *Materials Science and Engineering: A*. - 2014. - vol. 612. - pp. 440-444.

- [2] Smurov I. Yu. And others. Additive production using a laser // Vestnik MGTU Stankin. - 2011. - vol. 2. - №. 4. - p. 144-146.
- [3] Bashkirov E.R., Khorkov K.S., Kochuev D.A., Zhdanov A.V., Arakelyan S.M. Experimental studies of bulk samples from powder composite materials obtained by laser sintering. Fundamentalnye issledovaniya. - 2017. - № 3. - pp. 9-14;
- [4] Kostritsky V. V., Lisovskiy A. L. Increase of the absorbing ability of the surface layer of a metal during a laser action with the help of absorbing coatings. - 2013.
- [5] A.A. Voznesenskaya, L.V. Belyaev, D.A. Kochuev, D.M. Kononov, I.V. Shinakov, Investigation of the effect of carbon additive on the absorption of laser radiation in the selective laser melting of materials based on aluminum / Scientific and Technical Journal of the Volga region, 2018. - №1. - pp. 50-52. - ISSN 2079-5920. DOI: 10.24153 / 2079-5920-2018-8-1-50-52.

39. МЕТОД ЭЛЕКТРО-ИНДУЦИРОВАННОЙ ЛИТОГРАФИИ В ЗАДАЧЕ НАБЛЮДЕНИЯ ТАММОВСКОГО ПЛАЗМОНА

А. Шагурина¹, А. Лелекова¹, А. Кель¹, С. Кутровская^{2,1}

¹ *Владимирский государственный университет имени А.Г. и Н.Г. Столетовых (ВлГУ),
Владимир, Россия*

² *Университет Вестлейка, Ханчжоу, Китай
89004757040, shagurina.a@mail.ru*

Формирования металлических наноструктур из благородных металлов, обладающих уникальными оптическими свойствами, возникающих при возбуждении локализованных плазмонных резонансов, вызывает в последнее время особый интерес в связи с многочисленными их применениями [1,2]. Использование плазмон-поляритонных наноструктур для оптических элементов позволит значительно уменьшить размер интегральных схем, в которых будет реализовано возбуждение и направленное распространение поверхностных электромагнитных волн. Свойства ТЕ и ТМ таммовских мод демонстрируют сильную зависимость энергии от геометрических параметров волновода [3], в связи с чем возникает необходимость точного контроля данных параметров, а, следовательно, необходимы новые высокоточные методы создания металлических структур.

Из множества существующих способов по созданию структур в соответствии с заранее подготовленным шаблоном выделяется широко известный и относительно недорогой метод зондовой литографии, позволяющий создавать структуры с нанометровым пространственным разрешением. В нашем случае литографический рисунок формируется методом электроиндуцированной литографии с помощью СЗМ на базе платформы зондовой нанолaborатории NTEGRA Aura в контактном режиме работы АСМ [4]. Нами реализована схема, где зонд и подложка представляют собой электроды, инициирующие электрохимическую реакцию, протекающую в водном мениске под проводящей иглой. Процесс осаждения металлического нанослоя определяется величиной напряжения смещения зонд-подложка в диапазоне 6-10 В, а увеличение толщины достигается путём многократного повторения литографического процесса. Минимальный размер получаемого элемента в плоскости сканирования ограничен диаметром водного мениска, где протекает реакция диссоциации водно-солевого раствора металла. В работе было исследована зависимость качества литографического рисунка от концентрации солевого раствора металла. Для наблюдения распространения таммовского плазмона данным методом были выращены 3 образца с протяженными металлическими треками на поверхности брегговского зеркала различной толщины: 5 нм, 50 нм, 500 нм. Возбуждение и детектирование поверхностных плазмонов на краях металлической полосы осуществлялось с использованием сканирующей микроскопии ближнего поля (СБОМ) Ntegra Spectra. На рисунке 1 представлено распределение электромагнитных волн в ближнем поле для металлических треков различной толщины. Значительные проявления максимумов интенсивности светового поля, которые отвечают образованию связанных состояний среда-свет зафиксированы при высоте металлического слоя 50 нм (рисунок 1б).



Рисунок 1. Распределение отклика электромагнитной волны, зафиксированной в ближнем поле вблизи металлического трека различной толщины: а) 5 нм; б) 50 нм; в) 500 нм.

Работа выполнена в рамках гранта РФФИ № 16- 541 32-60067-mol_a_dk, при частичной поддержке Президента Российской Федерации в рамках программы государственной поддержки молодых российских ученых, грант № МК-2842.2017.2 и Министерства образования и науки Российской Федерации, проект №. 16.1123.2017 / 4.6.

- [1] Chen J. Li Y., Lu W., Qi J., Cui G., Liu H., Xu J. and Sun Q. 2007 J Appl. Phys. 102 113109.
- [2] Maier S.A. 2011 Plasmonics: fundamentals and applications Izhevsk 278.
- [3] Chestnov I.Yu., Sedov, E.S., Kutrovskaya, S.V., Kucherik, A.O., Arakelian, S.M., Kavokin A.V. 2017 J Physical Review B. 96 245309.
- [4] Kucherik A., Kutrovskaya S., Skryabin I., Shagurina A., Osipov A., Chesnov I. 2017 Progress In Electromagnetics Research Symposium - Spring (PIERS) 1001-1004

40. THE MEASUREMENTS OF LASER RADIATION PARAMETERS AT ITS REGISTRATION ON A DIFFUSELY REFLECTING SHIELD

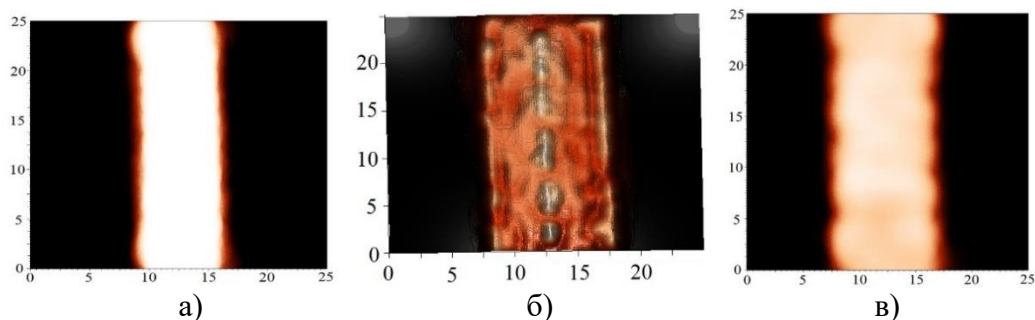
A. Antipov, E. Artyukh, I. Boganova, A. Karpov, A. Morozova, A. Shepelev

FSE «SLR «Raduga», Vladimir region, Raduzhniy, tel. (49254) 3-30-30,
e-mail: raduga@trassa.org

The intensive development of laser physics and laser technologies has led to the creation of laser complexes and systems for special purposes, which are used in various fields of science and technology. In all these areas, related to both the use of lasers and their creation and testing, the problems of measurement of radiation parameters and characteristics are particularly acute [1].

Spatio-energy parameters and characteristics of laser radiation play an important role in almost all applications of laser systems and complexes along with energy ones: angular and energy divergence, coordinates of the spot energy center, relative distribution of power and energy density in the beam cross section [2].

The possibility of measuring the parameters of wide-aperture laser beams at a great distance from the source is of particular interest. This is especially important in the course of route tests of laser systems and complexes.

Thus, an important task is adjustment of measuring algorithms the parameters of laser radiation in laboratory and field conditions.

A promising method for solving such problems is the developed method of measurements based on the parallel transformation of the energy (power) of radiation by a matrix photo detector at various points of the projective image of the radiation distribution in the cross section of the laser beam on a diffusely reflecting shield.

The parameters of laser radiation are determined by the results of image processing of the registered distribution of power density (energy) in the package of applications for receiving and processing television images «SyncLang» [3].

The developed specialized software performs the following functions in the measurements process:

- control of the images registration process of power density (energy) distribution of laser radiation on the diffusely reflecting shield;
- processing of images received as a registration result;
- saving and documenting of measurement results.

It is possible to determine the following parameters of laser radiation as a result of image processing by this method:

- relative distribution of the energy density (power) of radiation (RDED), (RDPD) in the laser beam cross section;
- dimension of RDED (RDPD);
- radiation divergence;
- coordinates of the energy center of the RDED (RDPD) of the radiation beam section;
- coordinates of the geometric center of the RDED (RDPD) of the radiation beam section;
- deviation of the coordinates of the energy center of the RDED (RDPD) section of the radiation beam from the aiming point;
- laser radiation power (pulse energy).

- [1] 1. Zubov V.A. Measurement methods of laser radiation characteristics. – M.: Science, 1973. 192 p.
- [2] 2. Measurement of energy parameters and characteristics of laser radiation. Edited by A.F. Katyuk – M.: «Radio and communication», 1981. 288 p.
- [3] 3. Yane B. Digital image processing. – M.: «Technosphere», 2007. 584 p.

41. SYNTHESIS OF TITANIUM NANOTUBES DOPED WITH NPS OF NOBLE METALS

I. Skryabin¹, A. Kucherik¹, A. Osipov¹, S. Kutrovskaya^{2,1}

¹*Department of Physics and applied mathematics, Stoletov Vladimir State University, 600000 87 Gorky str, Vladimir, Russia*

²*Institute of Natural Sciences, Westlake University, No.18, Shilongshan Road, Cloud Town, Xihu District, Hangzhou, China*

**Email: skryabin@vlsu.ru*

Nanostructured titanium dioxide is a material possessing a number of unique properties as chemical and mechanical stability, photocatalytic, optical nonlinearity, transparency in the visible frequency range, which makes it extremely promising for various applications such as photonic devices, elements for solar energy and so on. Significant changing of its properties can be realized due the doping by metallic nanoparticles, for example, the spectral absorption band widens up to the visible range due to resonances on plasmons. The intensity and a spectrum composition of a resonant absorption depend on the material, a concentration and a distribution of the used metal nanoparticles (silver, gold) in the dielectric matrix. The using of nobel metals in a titanium dioxide matrix makes it possible to implement a metamaterial with hyperbolic dispersion in the visible region of the spectrum [1], which opens the possibility for creating an ideal absorber of the dark UV and visible ranges.

In this work we propose a method of the formation of quasiperiodic structures based on the effect of self-assembly of titanium dioxide microtubules at the process of laser ablation of a titanium target at an inhomogeneous magnetic field [2]. During a self-organization process of the obtained porous film of titanium dioxide, colloidal nanoparticles of gold and silver were added into its structure. The emerging two-dimensional structures exhibit the properties of the enhancement of absorption of optical radiation near plasmon resonances of silver and gold [3]. The absorption peaks are shifted and modified depending on the concentration of the nanoparticles being implanted and the structure of the titanium dioxide matrix. se components, incorporating the applicable criteria that follow.

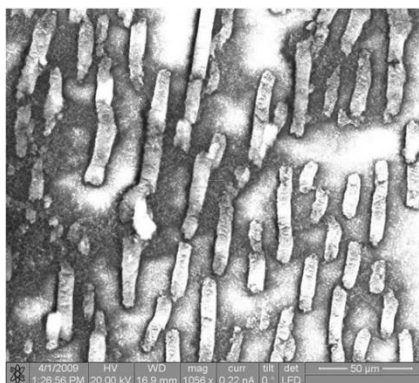

a)

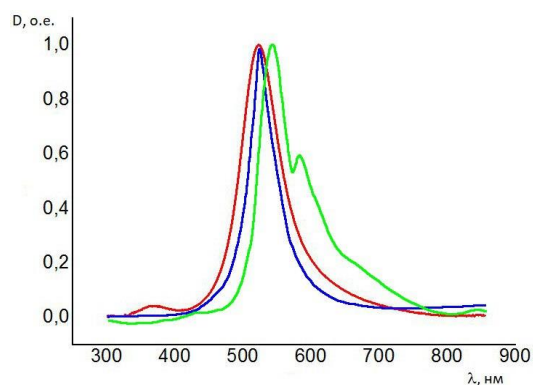

b)

Fig.1 a) SEM image of the surface of a layer grown by laser ablation with 100-ns pulses at an average power of 10 W, beam scan speed of 1 mm s⁻¹ and pulse repetition rate of 60 kHz; b) changes of optical properties of doped materials: red curve is an absorption of gold NPs; blue curve is an absorption of gold NPs deposited on a porous titanium thin film; green curve is an absorption of titanium tubes doped golden NPs.

This study was supported by the Ministry of Science and Higher Education of the Russian Federation (state project no. 16.1123.2017/4.6).

- [1] Poddubny, A., Iorsh, I., Belov, P. & Kivshar, Y. *Nat. Photon.* **7**, 948–957 (2013).
- [2] A. Antipov, S. Arakelian, S. Kutrovskaya et al. *Quantum Electron.* **40**, 7 (2010).
- [3] Arakelyan, S. M., Veiko, V. P., Kutrovskaya, et al. *J. Nanopart. Res.* **18**, 155 (2016).

42. LOCALIZATION OF AN ELECTRIC ARC DISCHARGE IN A LASER-INDUCED PLASMA CHANNEL

A. Ivashchenko, D. Kochuev, R. Chkalov, K. Khorkov, V. Prokoshev

*Department of Physics and Applied Mathematics,
Vladimir State University named after A. G. and N. G. Stoletovs, 87 Gorky, Vladimir,
600000, Russia*

Tel.: +79049552142, e-mail alenaenergie@gmail.com

The laser beam is a high-precision, wear-free tool with a wide range of properties. Laser treatment often raises the question of the lack of power in the field of laser radiation. In a number of applications, this can be achieved by using additional sources of energy. When focusing the laser beam into a region of space, it is possible to create conditions for the propagation of electric energy. The study of the processes of formation of conducting channels, as well as the transmission of electric energy through them, is of great interest [1-3]. The use of laser radiation to form an electrically conductive channel is a promising and developing direction.

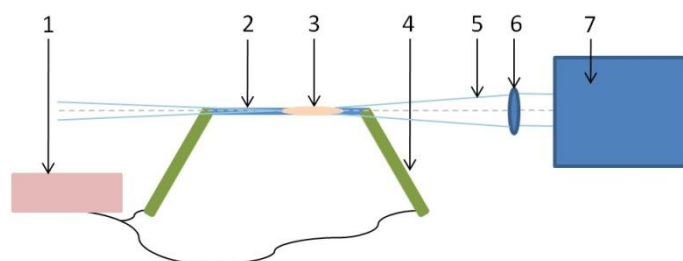

Fig. 1. The scheme of the experiment: 1 – high voltage DC source, 2 – electric arc discharge, 3 – optical breakdown area, 4 – tungsten electrode, 5 – laser beam, 6 – focusing lens, 7 – laser system

The experiment was carried out using the femtosecond ytterbium laser system TETA-10 with the following parameters: the wavelength – 1029 nm, the pulse duration – 280 fs, repetition rate – up to 10 kHz, pulse energy – 150 μ J. Polarization of the laser radiation is linear. During the experiment the pulse repetition rate varied from 0.1 to 10 kHz. The plano-convex lens was used to focus the laser radiation, the focal length – 50 mm. Figure 1 shows the scheme of the experiment. The electric arc was generated by a high voltage DC source. The discharge voltage – 25 kV, generation frequency – 100 Hz. The discharge was carried out through the air gap between the tungsten electrodes spaced at a distance of 10 mm under the normal conditions without the use of gases. The caustic area was located at a distance of 0.8-0.9 mm above the right electrode.

The paper considers the influence of laser radiation parameters on the nature and dynamics of the electric arc propagation. The dependences of the arc discharge behavior on the average laser radiation power, pulse repetition rate, and the spatial shape of the laser-induced plasma channel are obtained.

Figure 2 (a,b) shows photographs of the propagation process of the electric arc along the area of optical breakdown at different laser pulse repetition rates. A circle designates the region of optical breakdown.

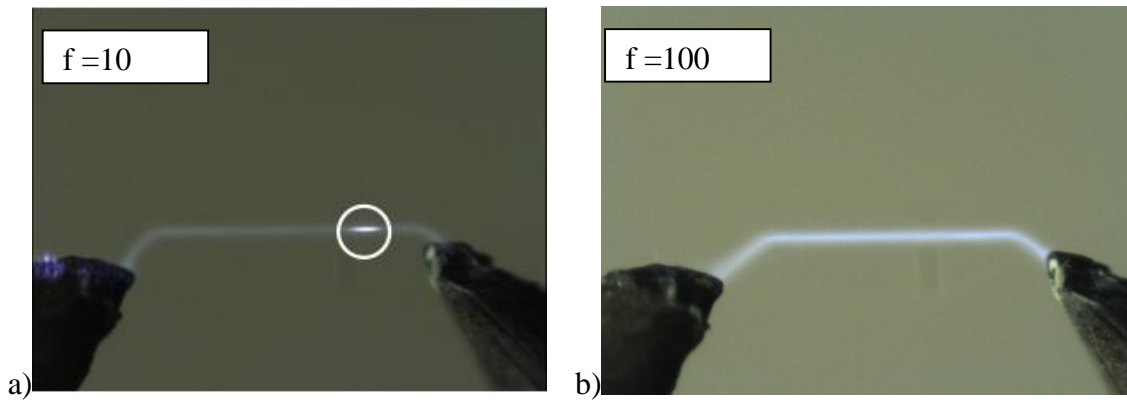

Fig.2. The flow of an electric arc through the plasma channel, an average power of laser radiation –1.5 W

Thus, the propagation of the electric arc occurs strictly through the induced plasma channel, which opens up wide possibilities for controlling the electric arc discharge using laser radiation.

- [1] Apollonov V.V., Pletnev N.V. Creation of long conducting channels in the atmosphere. "Quantum Electronics", 42, №2, 2012, p.130-138
- [2] Zvorykin V.D., Levchenko A.O., Smetanin I.V., Ustinovsky N.N. Creation of extended plasma channels in the atmosphere for directional transmission of energy of electromagnetic radiation or electric current. Innovation and Expertise,1, № 10, 2013, p. 16-24
- [3] Ionin A.A., Kudryashov S.I., Levchenko A.O. et al. Triggering and guiding electric discharge by a train of ultraviolet picosecond pulses combined with a long ultraviolet pulse. Appl. Phys. Letters, Vol. 100, 2012, 104105

43. FORMATION OF ANTIFRICTION SURFACE-PERIODIC NANOSTRUCTURES UNDER THE ACTION OF ULTRASHORT LASER PULSES

A. Voznesenskaya, D. Kochuev, A. Zhdanov, K. Khorkov, V. Morozov

*Vladimir State University named after A. G. and N. G. Stoletovs,
87 Gorky, Vladimir, 600000, Russia
tel.: +7-920-913-88-87, e-mail: 2obk@bk.ru*

Laser-induced periodic surface structures (LIPSS) are a unique phenomenon that can be observed on virtually any material after irradiation with its linearly polarized laser beams, especially when using femtosecond laser radiation [1-3]. Over the past few years, the research activity in the field of LIPSS has significantly increased, since their generation in a one-step process provides a simple method of nanostructuring and surface functionalization for controlling optical, mechanical or chemical properties. After exposure to the metal with femtosecond radiation, the surface of the sample acquires a smaller coefficient of friction and wear, which underlines the enormous potential of LIPSS in tribological applications. The coefficient of friction decreases more than twofold [4].

Frictional qualities are affected by the microstructure of the surface, namely a certain degree of roughness or porosity, in which oil is retained in depressions and pores. The appearance of antifriction properties under conditions of dry friction is facilitated by the presence in the material of such components, which, themselves having a lubricating action and present on the friction surface, provide low friction [5]. An approach is widely used to reduce the friction coefficient by applying lubricants. Due to the grooves and roughness available on the surface, the grease remains in the grooves. This effect allows the lubricant to stay longer between rubbing planes.

As a radiation source, the femtosecond laser system TETA-10 was used in this work. Parameters of laser radiation: the duration of the radiation pulse is $\tau = 300$ fs and the energy in the pulse is $\varepsilon = 150$ μ J. The sample was a round plate of molybdenum. The sample prepared for the experiment was placed on a stage and subjected to laser treatment. Further, the dependence of the period of the formed ripple structures on the orientation angle of the sample was established. During the experiment, the power value was 1.2 W and the sample travel speed was 1 mm / s. With the help of the motorized rotary translator Standa 8MR151, the sample was set to: $\theta = 0; 5; 15; 25; 35; \text{ and } 45$ degrees, then laser radiation passes through the focusing lens, after which the strokes begin to form at a speed of 1 mm / s.

The studies of the formed periodic surface structures resulting from the action of femtosecond laser radiation were made on the basis of the obtained images from a scanning electron microscope Quanta 200 3D. The criterion for determining the best processing regimes was to obtain well-formed periodic structures, without any pronounced defects in the form of spalling melt ablation or a phase explosion.

Investigation of the coefficient of friction on the surface of molybdenum before and after treatment was carried out on a CSM tribometer. The laser-induced periodic surface structures formed on the molybdenum surface reduced the friction coefficient by 50%. After exposure to the metal with femtosecond laser radiation, the sample surface acquired a smaller coefficient of friction and wear, which underlines the enormous potential of laser-induced periodic surface structures in tribological applications. The developed microrelief of the surface in addition to the functions of retaining the lubricant helps to reduce the contact area upon contact of the conjugated friction pairs. The considered

method for the formation of periodic surface structures can be used in industry when processing friction pairs to increase the antifriction properties.

- [1] Khorkov K.S., Abramov D.V., Kochuev D.A., Bashkirov E.R., Chernikov A.S., Arakelyan S.M., Prokoshev V.G. Femtosecond laser nanostructuring of tungsten surface // News of the Russian Academy of Sciences. The series is physical. - 2017.-vol.81. - №12. - pp.1619-1623.
- [2] Abramov D.V., Arakelyan S.M., Makov S.A., Prokoshev V.G., Khorkov K.S. Formation of a system of microcraters on the surface of titanium under the action of femtosecond laser radiation under conditions of rapid cooling // Letters to the Journal of Technical Physics. - 2013. - vol.39. - №16. - pp.14-22.
- [3] Barberoglou M. et al. The influence of ultraviolet radiation through irradiation. 2. - pp. 273-283.
- [4] Bonse J. et al. Applied physics A. - 2014. - vol. 117. - №. 1. - pp. 103-110.
- [5] Kononov D. M., Zhdanov A. V., Korolev A. N. Study of the properties of nanostructured carbon-based PVD coatings // Modern problems of science and education. - 2011. - № 6. - pp. 130-130.

44. PHOTOACOUSTIC INVESTIGATION OF ABLATION DYNAMICS DURING DOUBLE-PULSED FEMTOSECOND LASER PROCESSING OF SILICON AND ALUMINUM

Y. Golubev, A. Samokhvalov, D. Polyakov, S. Shelygina and V. Veiko

*ITMO University, 49 Kronverksky Pr., St. Petersburg, 197101, Russia
+7 (921) 443-55-24, samokhvalov.itmo@gmail.com*

Femtosecond laser treatment is securing its place as one of the leading methods of the processing of metals, semiconductors and dielectrics [1]. Femtosecond laser techniques include double-pulsed regime, which introduces a new degree of freedom into the process, namely the delay between the pair of pulses, which allows better control of it. The aim of this work is to study the dynamics of ablation during femtosecond laser processing depending on the delay between the pulses.

One of the interesting methods of studying laser-matter interaction process is photoacoustics [2]. In our experiments, we used Avesta-Project laser system ($\lambda = 800$ nm, $\tau = 100$ fs, $E = 1$ mJ), a plate of silicon, aluminum and an ultrasound transducer with 5 MHz passband. Samples was subjected to single-pulse irradiation with various pulse energy and double-pulse irradiation with the delay varying from 330 fs to 4 ns. Photoacoustic signal amplitude, transient time and FWHM were measured, as well as crater diameters.

Results show that for silicon, with increasing the delay up to 500 ps, the amplitude of the signal gradually increases, while transit time gradually decreases. When subjecting aluminum to double-pulsed femtosecond laser action with fluence slightly larger than ablation threshold, effective formation of "nanofoam" structures can be observed.

For silicon and aluminum, double-pulsed femtosecond laser regime doesn't significantly lower ablation threshold compared to single-pulse regime. At delays more than 30 ps, the second pulse interacts with expanding matter that appears after the ablation with the first pulse. Redeposition of matter in the process of double-pulsed femtosecond laser action leads to the change of the dynamics of ablation processes and the formation of "nanofoam" structures.

The work was carried out with financial aid of RFBR grant МОЛ_a №18-32-00839.

- [1] Gaudio, Caterina, et al. "Incubation during laser ablation with bursts of femtosecond pulses with picosecond delays." *Optics express* 26.4 (2018): 3801-3813.
- [2] Potemkin, F.V., et al. "Two-dimensional photoacoustic imaging of femtosecond filament in water." *Laser Physics Letters* 15.7 (2018): 075403.

45. THE LASER-ASSISTED SYNTHESIS OF LINEAR CARBON CHAINS STABILIZED BY NOBLE METAL PARTICLES

A. Osipov¹, A. Kucherik¹, S. Kutrovszkaya^{1,2}, I. Skryabin¹, S. Arakelian¹

¹ Department of Physics and applied mathematics, Stoletov Vladimir State University, 600000 87 Gorky str, Vladimir, Russia

² Russian Quantum Center, 143025 Novaya street, Skolkovo, Moscow Region, Russia

*Email: osipov@vlsu.ru

Abstract — Metal-carbon materials realize surface-enhanced Raman scattering. Such structures were synthesized using the laser irradiation of colloidal systems consisting of carbon and noble metal nanoparticles.

Synthesis of new carbon form is an actual task of modern nanotechnology. Laser methods for the synthesis of nanostructured carbon allows to vary the composition and morphology of the structures obtained according to the experiments conditions. In our experiments, we demonstrate the synthesis of carbyne with the irradiation of the colloidal system obtained during laser ablation of a schungite target in water. Also, adding nanoparticles of noble metals in obtained colloidal system and extra laser irradiation of in results in the producing of metal-carbyne particles (carbon chains anchored by metal nanoparticles). Our experiments suggest that a change in the conditions of exposure (the exposure time and the energy of the impact) by YAG:Nd laser with a pulse duration of 10 ns leads to the controlled formation of metal-carbyne structures.

In our experiments, the proposed method is based on the laser irradiation of colloidal systems consisted of shungite and noble metal (Au and Ag) nanoparticles. Such colloidal system is placed under Yb-fiber laser (1.06 μm) with a pulse duration of 100 ns and a pulse energy of up to 1 mJ, and the process results in the fabrication of LLCC in liquid. The mechanism for that realizes because of the homogeneous symmetry interaction in liquid for the carbon system that stabilizes the linear structure. In this study, we have analyzed the possibility of controlling the properties of fabricated composites by changing the irradiation conditions and the particle concentration in colloid. The laser irradiation of the colloidal system was performed by scanning a focused laser beam (focal spot diameter 5 μm) in a cuvette volume with a scanning speed of 50 $\mu\text{m/s}$; the total irradiation time was about 15 min.

The Raman spectra (fig. 1) shows the difference between carbyne colloidal system without metal particles (left) and including them (right). The peak at 2100-2300 cm^{-1} and 1900-2200 cm^{-1} corresponds to the polyynes chains ($-\text{C}\equiv\text{C}-$)_n and cumulene chains ($=\text{C}=\text{C}=-$)_n respectively. The peak at 600-900 cm^{-1} is a mechanical stress in chains. The Raman spectra of the colloidal solution which includes noble metals (right) does not have any peaks near the frequency corresponding to the mechanical stress, the carbyne chains became stabilized by noble metal particles.

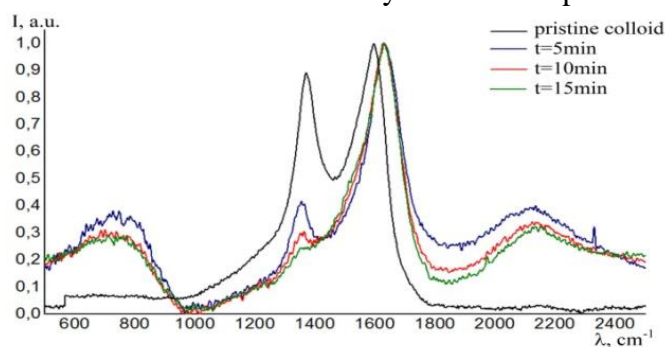

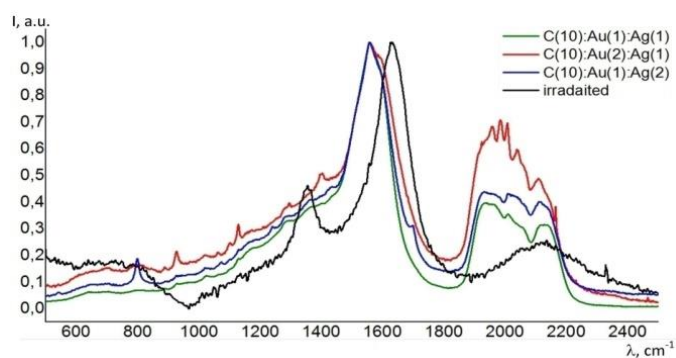

Fig. 1. Raman spectra of colloidal system with only carbon chains (left); and colloidal system with carbyne chains stabilized by noble metal particles (right).

The laser with nanosecond pulse duration allows to modify the structure of carbon bonds and creates best conditions for obtaining of linear carbon chains with different hybridization. The obtained structures are planned to be used for the registration of the effect of the SERS with the possibility of the sensitivity control in different areas of the spectra because of the changing of the initial component concentration and morphology

- [1] S. Kutrovskaya, S. Arakelian, A. Kucherik, A. Osipov, A. Evlyukhin, A. Kavokin The Synthesis of Hybrid Gold-Silicon Nano Particles in a Liquid, Scientific Reports, Volume 7, Issue 1. DOI: 10.1038/s41598-017-09634-y
- [2] S.M. Arakelyan, V.P. Veiko, S.V. Kutrovskaya, A.O. Kucherik, A.V. Osipov, T.A. Vartanyan., T.E. Itina J Nanopart Res (2016) 18:155. DOI 10.1007/s11051-016-3468-0.

46. STRONGLY-COUPLED ELECTRON AND NUCLEAR SPIN SYSTEMS IN INGAAS EPILAYERS

A. Evdokimov¹, M. Kuznetsova¹, M. Petrov¹, Y. Efimov², S. Eliseev², V. Lovtcius²,
P. Shapochkin²

¹Spin Optics Laboratory, Saint Petersburg State University, St. Petersburg, Russia

²Saint Petersburg State University, St. Petersburg, Russia

evdokimov.artiom@gmail.com

In semiconductor heterostructures, the absorption of circularly polarized light (optical pumping) leads to the formation of spin-oriented photoelectrons. In this case, the magnetic moments of the crystal lattice of the nuclei become polarized due to the hyperfine interaction with the polarized electron spins. As a result of this interaction, a strongly coupled electron-nuclear spin system is created [1].

We study the samples with the thick InGaAs epitaxial layers n-doped with Si. We measure the depolarization of photoluminescence in the external magnetic field applied perpendicular to the growth axis of the structure (the Hanle effect). Several samples are studied with different concentrations of donors: $n=10^{15} \text{ cm}^{-3}$ in the sample T776, $n=5 \times 10^{14} \text{ cm}^{-3}$ in the sample T777, and $n=10^{16} \text{ cm}^{-3}$ in the sample T769. In one of the samples, large degree of circular polarization of the photoluminescence is observed up to $\rho = 15\%$, see Fig. 1(a). This polarization degree is approximately 3 times larger than that in bulk GaAs with similar concentrations of donors [2]. The central peaks of the Hanle curves demonstrate very small width. This is clear indication of a high quality of the structures under study. The measured Hanle curves with continuous-wave (CW) excitation demonstrate a well-pronounced W-structure, which is evidence for a strong electron nuclear spin interaction.

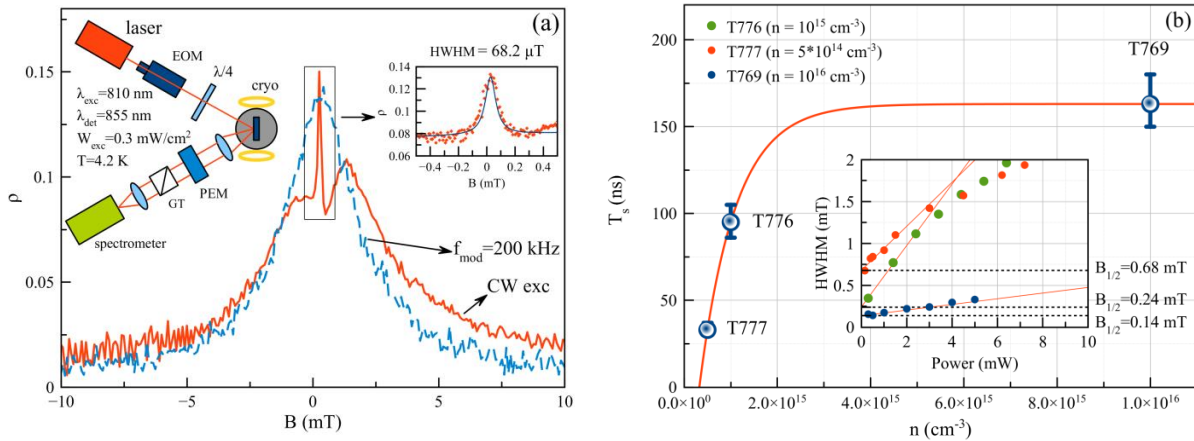

Fig. 1: (a) Hanle curve measured at the CW excitation (solid red line) and with modulation of the circular polarization of excitation (dashed blue line). Left inset is the schematic illustration of the experimental setup. Right inset shows the central part of the W-structure. (b) Dependence of the spin relaxation time on the donor concentration for three studied samples. Inset shows the power dependence of the Hanle curve widths.

Figure 1(b) shows the results of analysis of the experimental data measured with fast frequency of modulation of the circular polarization of excitation at different pump powers. The shape of the Hanle curves measured such way has a Lorentzian form and can be analyzed by the formula:

$$S(B) = \frac{S_0}{1 + \left(\frac{\mu_B g B T_S}{\hbar}\right)^2} = \frac{S_0}{1 + \left(\frac{B}{B_{1/2}}\right)^2},$$

where $B_{1/2}$ is the half width at half maximum (HWHM) of the curve. Values of $B_{1/2}$ given in the inset of Fig. 1(b) are obtained by extrapolation of its power dependence for each sample to zero. S_0 is the electron spin polarization at zero magnetic field, μ_B is the Bohr magneton, g is the electron g-factor, B is the applied magnetic field, and T_S is the electron spin relaxation time. The electron spin relaxation time can be found as $T_S = \frac{\hbar}{\mu_B |g| B_{1/2}}$. From the analysis we obtain relatively long electron spin relaxation times, $T_S=33$ ns for the sample T777, $T_S=95$ ns for the sample T776, and $T_S=163$ ns for the sample T769. The last value is comparable with that observed for the bulk GaAs with optimal doping [3].

The obtained results allow us to conclude that the studied samples are promising for the further study of electron-nuclear spin interactions and for the creation of a magnetically ordered nuclear spin system.

- [1] D. Paget, G. Lampel, and B. Sapoval, “Low field electron-nuclear spin coupling in gallium arsenide under optical pumping conditions”, *Physical Review B*, 15, 12 (1977).
- [2] P. S. Sokolov, M. Yu. Petrov, K. V. Kavokin, A. S. Kurdyubov, M. S. Kuznetsova, R. V. Cherbunin, S. Yu. Verbin, N. K. Poletaev, D. R. Yakovlev, D. Suter, and M. Bayer, “*Nuclear spin cooling by helicity-alternated optical pumping at weak magnetic fields in n-GaAs*”, *Physical Review B* 96, 205205 (2017).
- [3] R. I. Dzhioev, K. V. Kavokin, V. L. Korenev, M. V. Lazarev, B. Ya. Meltser, M. N. Stepanova, B. P. Zakharchenya, D. Gammon, and D. S. Katzer, “*Low-temperature spin relaxation in n-type GaAs*”, *Physical Review B* 66, 245204 (2002).

47. SELECTED TOPICS FROM NON-IDEAL STRUCTURE POLARITONICS

V. Rumyantsev¹, S.Fedorov¹, A. Kavokin²

¹*Galkin Institute for Physics & Engineering, Donetsk 83114, Ukraine,*

²*International Center for Polaritonics, Westlake University, Hangzhou, China*

tel.: +380 62 311 53 48, e-mail: 380957931135@yandex.ru

Fabrication of novel materials for the creation of sources of coherent radiation is presently a vast interdisciplinary area of theoretical and experimental investigations, which involve condensed matter physics, nanotechnologies, chemistry as well as information science [1]. Particular actuality is gained by the investigations into possibilities of alteration of physical properties of the resulting composite structures by application of suitable external actions (such as e.g. elastic stresses) and perspectives of controlling of electromagnetic wave propagation therein. The existing optoelectronic devices can be roughly divided into two types, namely those utilizing the disturbances of electronic subsystems of constituting materials, and those based on optical properties of the corresponding composite structures. In this connection some promising vistas can be opened by the so-called polaritonic crystals [2], which represent a particular type of photonic crystals featured by a strong coupling between quantum excitations (excitons) and electromagnetic waves. The growing necessity for examination of polaritonic structures gave rise to *polaritonics* as an independent branch of photonics. An example of polaritonic structure is provided by an array of coupled microcavities [3]. Optical modes in microcavity systems have been attracting a considerable attention due to the progress in fabrication of novel optoelectronic devices [4]. Microresonator systems can also be potentially utilized for manufacturing of exceptionally accurate optical clockworks [5]. Worthy of noting are the defect-based microresonators in photonic crystals [6], which were shown to strongly interact with quantum dots [7, 8]. Nanostructures such as microporous silicon [9], expected to solve the tasks of improvement of the functional complexity of the semiconductor devices.

In the present report we use the previously developed concepts of photonic structures to treat a nonideal polaritonic crystal formed by a topologically ordered array of coupled microcavities (resonators) containing a system of atomic clusters (quantum dots). Particular attention is paid to the sensitivity of the polaritonic spectrum on the geometry and key parameters of interacting photonic and electronic subsystems. Basing on the concepts of ideal polaritonic structures and on the previously developed theory of exciton-like electromagnetic excitations [10] we consider a non-ideal polaritonic 1D and 2D crystals as a systems of coupled microcavities (microresonators). It is of interest to consider an array of such resonators with embedded atomic clusters (quantum dots). The dispersion of electromagnetic excitations in a non-ideal 1D and 2D lattices of coupled microcavities as affected by the variable composition of quantum dots as well as by the variable distances between nearest-neighbor microcavities are studied. We also consider the effect of a uniform elastic strain on the energy spectrum of elementary excitations and optical properties of the system. It is shown that the presence structure defects in the resonator and atomic subsystems results in a substantial renormalization of polariton spectrum and thus in a considerable alteration of structure optical properties, leads to an increase in the effective masses of polaritons and hence to a decrease of their group velocity. The obtained numerical results contribute to our understanding of composite polaritonic structures and the prospects of their utilization for construction of solid-state devices with controllable propagation of electromagnetic waves.

- [1] M. Razeghi, *Technology of Quantum Devices*, Springer, New York, 2010.
- [2] E. S. Sedov, A. P. Alodjants, S. M. Arakelian, [Y.Y. Lin](#), [R.-K. Lee](#), Nonlinear properties and stabilities of polaritonic crystals beyond the low-excitation-density limit. *Phys. Rev. A* 84 (2011) 013813.
- [3] K.J. Vahala, Optical microcavities. *Nature* 424 (2003) 839.
- [4] M.A. Kaliteevskii, Coupled vertical microcavities. *Tech. Phys. Lett.* 23 (1997) 120.
- [5] S.B. Papp, K. Beha, P. Del'Haye, F. Quinlan, H. Lee, K.J. Vahala, S.A. Diddams, Microresonator frequency comb optical clock. *Optica* 1 (2014) 10.
- [6] J. Vučković, M. Loncar, H. Mabuchi, A. [Scherer](#), Design of photonic crystal microcavities for cavity QED. *Phys. Rev. E* 65 (2001) 016608.
- [7] D. Englund, A. Majumdar, A. Faraon, M. Toishi, N. Stoltz, P. Petroff, J. Vučković, Resonant excitation of a quantum dot strongly coupled to a photonic crystal nanocavity. *Phys. Rev. Lett.* 104 (2010) 073904.
- [8] V.V. Romyantsev, S.A. Fedorov, K.V. Gumennyk, D.A. Gurov, A.V. Kavokin. Effects of elastic strain and structural defects on slow light modes in a one-dimensional array of microcavities. [Superlattices and Microstructures](#). 120 (2018) 642-649.
- [9] [Jian Zhao](#), [Gaoxing Luo](#), [Jun Wu](#), [Hesheng Xia](#). Preparation of Microporous Silicone Rubber Membrane with Tunable Pore Size via Solvent Evaporation-Induced Phase Separation. *ACS Appl. Mater. Interface* 2013; 5 (6): 2040-2046
- [10] V.V. Romyantsev, S.A. Fedorov, K.V. Gumennyk, M.V. Sychanova, A.V. Kavokin, Exciton-like electromagnetic excitations in non-ideal microcavity supercrystals. *Nature Sci. Rep.* 4 (2014) 6945.

48. MODEL OF DIFFUSION PACKING COLLOIDAL PARTICLES

A. Istratov, D. Bukharov, V. Samyshkin, M. Gerke, S. Arakelian

*Vladimir State University named after A. G. and N. G. Stoletovs, 87 Gorky, Vladimir, 600000,
Russia
laser@vlsu.ru*

This paper describes a computer model for the formation of thin films by sedimentation of colloidal particles with allowance for surface diffusion with various methods of self-organization. The process of organizing such films can be likened to the free fall of identical balls that form an organized structure. Understanding the self-assembly mechanisms of nanoparticles is an important step in the direction of creating new materials with regard to optical and electrical properties.

Even at the early stage of thin-film research, it soon became clear that it was necessary to understand the mechanisms that control and determine the growth of thin films in order to achieve good control over these new materials. Hence the great efforts of the scientific community to characterize optimize and understand the growth of thin films. In connection with the need for a high degree of control over the properties of the films obtained a computer model was proposed which is a stochastic cellular automaton. This model is of interest due to simple deterministic rules that allow modeling not only the processes of deposition, but also the diffusion of deposited particles on the surface.

In this paper, the processes of deposition of thin films on a substrate of the same material, forming a crystalline structure were considered. The homoepitaxial growth of thin films is considered because the crystal structure does not change with the growth of the film; therefore, it is assumed in the model that particles can occupy only ideal crystallographic positions.

In this model, seven possible spatial lattices were considered: three of which have a rectangular grid at the base and four that have a triangular grid at the base. Also these spatial lattices are divided according to the type of fixing of new particles relative to the previous monolayer.

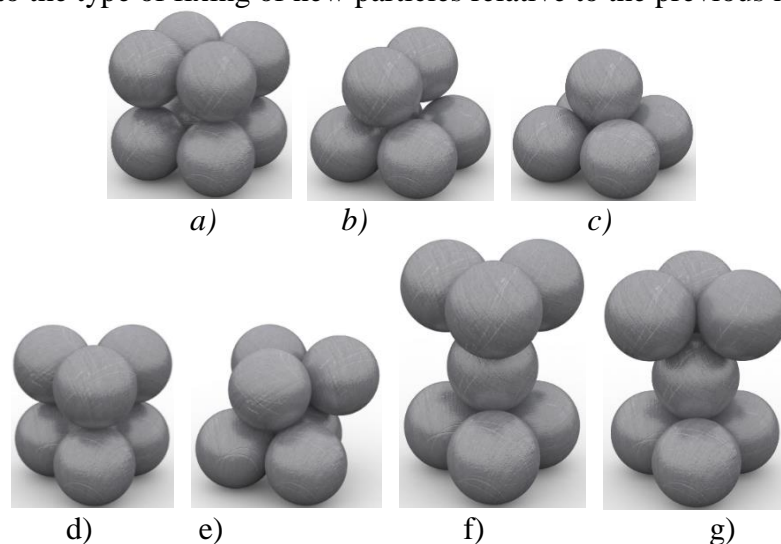
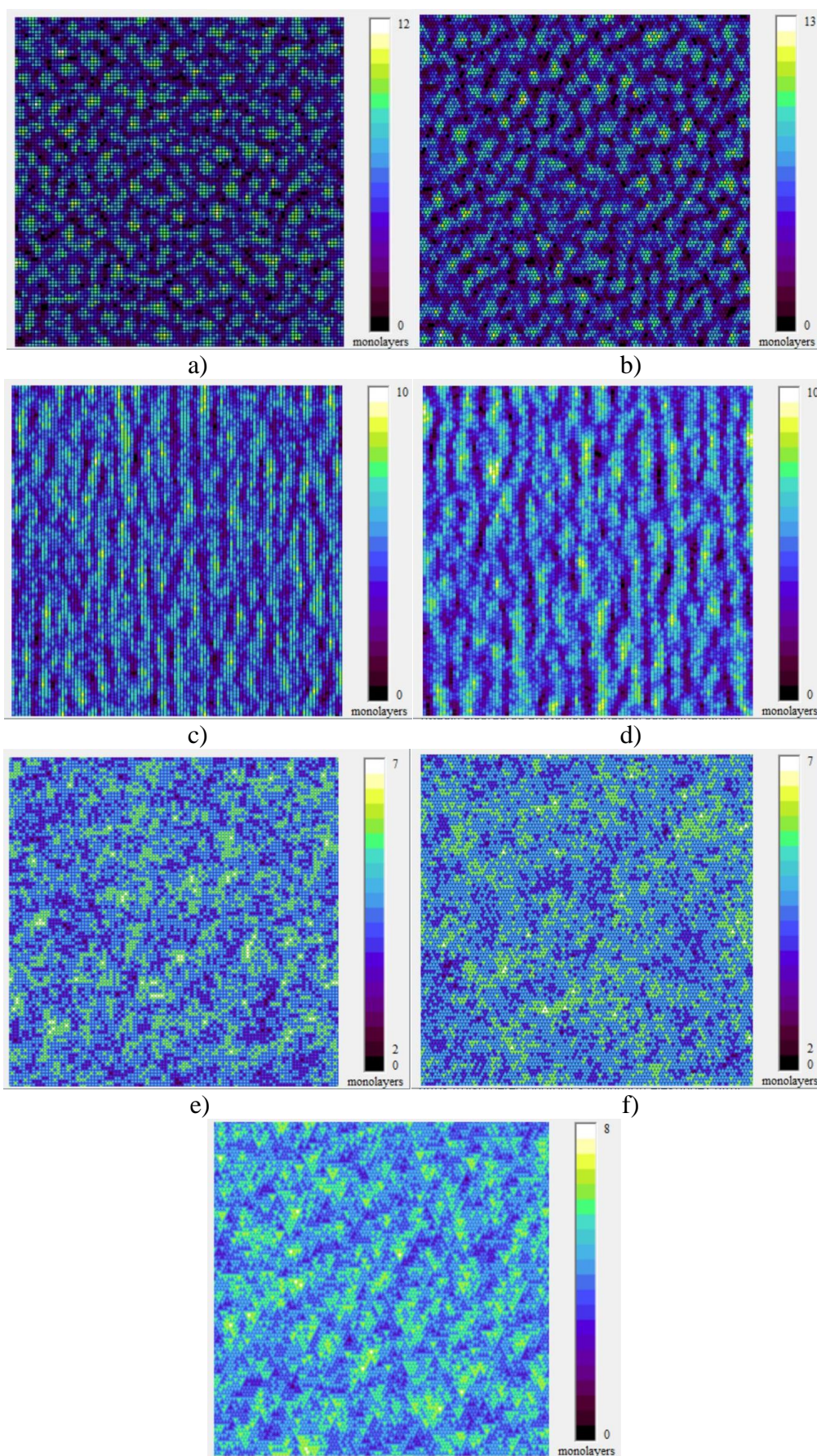

Figure 1. Particles deposited according to the proposed spatial lattices

All new particles are considered identical and their places of deposition are chosen randomly, and more than one particle is not deposited in a single cell of the surface in one simulation step. The number of particles that hit the surface in one simulation step determines the deposition rate of particles. Upon completion of the deposition of new particles for each of the points of the surface in which the new particle is located and its nearest neighboring points, the probabilities of diffusion of the particle are calculated. After that, in accordance with the calculated probabilities, the particle diffuses to the corresponding point on the surface.

In consequence of the numerical calculations, the following images of the surfaces of the obtained colloidal structures were obtained:



g)

Future 5. Simulated colloidal structures. The deposition time is 50 simulation steps. The deposition rate is 0.1 monolayer per simulation step. The average film thickness is 5 monolayers.

Spatial lattice:

a) Figure 1a; b) Figure 1d; c) Figure 1b; d) Figure 1e; e) Figure 1c; f) Figure 1f; g) Figure 1g.

This study was supported by the Ministry of Science and Higher Education of the Russian Federation (state project no. 3.7530.2017/8.9) and by the grant of president of Russian Federation by project MK-2842.2017.2.

- [1] Choi, J. J., Bian, K., Baumgardner, W. J., Smilgies, D.-M., Hanrath, T. Interface-induced Nucleation, Orientational Alignment and Symmetry Transformations in Nanocube Superlattices. *Nano Letters* 2012, 12, 4791–8.
- [2] Dong, A., Ye, X., Chen, J., Murray, C. B. Two-dimensional Binary and Ternary Nanocrystal Superlattices: The Case of Monolayers and Bilayers. *Nano letters* 2011, 11, 1804–9.
- [3] Freund, L. B., Suresh, S. *Thin Film Materials: Stress, Defect Formation and Surface Evolution*; Cambridge University Press, 2003.
- [4] Henzie, J., Grünwald, M., Widmer-Cooper, A., Geissler, P. L., Yang, P. Self-assembly of Uniform Polyhedral Silver Nanocrystals into Densest Packings and Exotic Superlattices. *Nature materials* 2012, 11, 131–7.
- [5] Kohler U., Jensen C., Reshort K., et. al. Homo- and heteroepitaxy of metal on metal growth// *Structure dynamics in heterogeneous systems.*-Singapore: World Scientific, 2001.- P. 140-147.
- [6] Mahan J. E. *Physical Vapor Deposition of Thin Films.* - Wiley-Interscience. 2000. - 336p.
- [7] Mills, D. L., Bland, J. A. C. *Nanomagnetism: Ultrathin Films, Multilayers and Nanostructures*; Elsevier Ltd, 2005.
- [8] Pulker, H. K. Characterization of Optical Thin Films. *Applied Optics* 1979, 18, 1969–77.
- [9] Smith R. W., Srolovitz D. J. Void formation during film growth: A molecular dynamics simulation study// *J. Appl. Phys.*- 1996.-Vol. 79.- P. 1448-1457.
- [10] Srolovitz D. J., Mazor A., Bukiet B. G. Analytical and numerical modeling of columnar evolution in thin films // *J. of Vac. Science & Technology.*-1988.- Vol. A6.- P. 2371-2380.
- [11] Venables, J. A. *Introduction to Surface and Thin Film Processes*; Cambridge University Press, 2000.
- [12] Venables, J. *Introduction to Surface and Thin Film Processes.* - Cambridge: Cambridge University Press, 2000. - 372p.
- [13] Woodruff, D. P., Delchar, T. A. *Modern Techniques of Surface Science*; Cambridge University Press, 1994.

49. SYNTHESIS AND CHARACTERIZATION OF NEW HYBRID MATERIAL BASED ON MWCNTS DECORATED WITH TITANIUM CARBIDE NANOCOATINGS WITH DIFFERENT MORPHOLOGY AS REINFORCING COMPONENTS OF ALLOYS

A. Aborkin¹, K. Kremlev², A. Obiedkov², B. Kaverin², N. Semenov², G. Zabrodina²

¹Vladimir State University named after Alexander and Nikolay Stoletovs, Vladimir, Russia

²G.A. Razuvaev Institute of Organometallic Chemistry of RAS, Nizhny Novgorod, Russia

e-mail: aborkin@vlsu.ru

Synthesis of new hybrid materials based on multiwalled carbon nanotubes (MWCNTs) and nanoscale coatings is a very promising direction of materials research, since such objects can be used as reinforcing fillers in various alloys and composites. The most relevant for such studies are hybrid materials based on MWCNTs and nanoscale coatings of titanium carbide. Such objects, due to the combination of their expected properties, can greatly improve the strength characteristics of various alloys and composites, in particular aluminum-based alloys.

To create such hybrid materials, the initial MWCNTs were first synthesized, and then the nanocoating coatings of titanium carbide were deposited on their surface by the MOCVD method. Synthesis of the source MWCNTs was carried out by MOCVD method also and is described in detail in [1]. Ferrocene and toluene were used as precursors. The ferrocene evaporator furnace temperature was 95 °C. The temperature of pyrolysis furnace was 825 °C. Flow rate of argon was 450 cm³/min.

Deposition of titanium carbide coatings was carried out in vacuum glass reactor. The synthesis procedure is similar to that used in [2]. Cp₂TiCl₂ and source MWCNTs were used as precursors and were placed into reactor before synthesis. Then reactor was heated up to 900 °C. Various parameters of synthesis have been used to study the various deposition modes of coatings. Thus, the initial mass ratio of MWCNTs and Cp₂TiCl₂ was 1:3, 1:4, 1:5, and 1:6 respectively.

Synthesized hybrid materials were analyzed by various physicochemical methods. With the help of XRD, it is established that the samples contain only two phases – carbon nanotubes and a phase of titanium carbide (Figure 1).

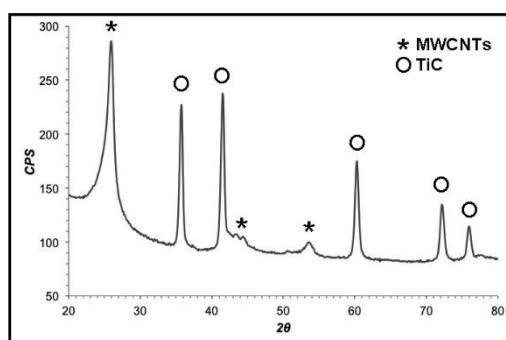

Figure 1. XRD pattern of synthesized hybrid material based on MWCNTs and nanoscale coatings of titanium carbide.

With the help of a scanning electron microscope, it was found several morphological types of a new hybrid material, depending on the initial ratio of MWCNTs and Cp₂TiCl₂. Thus, the first type is the titanium carbide coating deposited on the MWCNTs surface in the form of thin films. The thickness of continuous coatings is from 10 to 30 nanometers, depending on the features of the structure of the MWCNTs surface (Figure 2, a). Another detected morphological type is

TiC/MWCNTs in the form of columnar structures with an advanced surface of titanium carbide. In length, such structures reach 300 nm at a thickness of about 40 nm (Figure 2, b). The third type of object is the so-called whiskers – a kind of a crystal with a ratio of length to diameter > 100 . On average, the cross section of such whiskers is about 300 nm, and the length is of the order of hundreds of microns (Figure 2, c). Finally, the fourth type of discovered objects is the so-called mesocrystals of titanium carbide with classical outer shape. Such crystals are uniformly distributed throughout the sample volume and are rather firmly fixed both on the beams and on single MWCNTs (Figure 2, d).

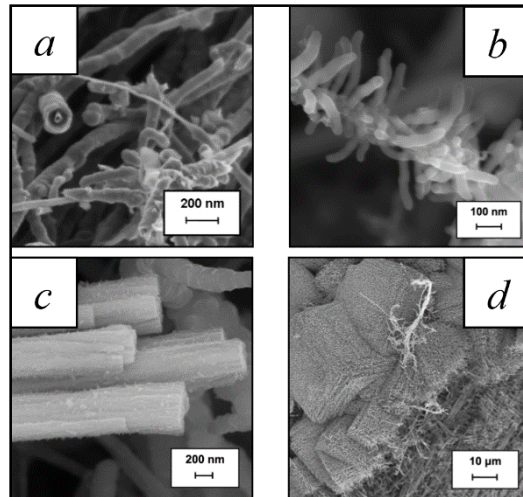

Figure 2. SEM micrographs of hybrid materials synthesized with different initial precursor ratios.

As a result of this study different types of new hybrid material TiC/MWCNTs synthesized using the MOCVD method were discovered, which can be tested as fillers in various aluminium matrix composites to improve their strength properties.

This work was supported by the RSF (Project 18-79-10227).

[1] Obiedkov A.M., Kaverin B.S., Egorov V.A., Semenov N.M., Ketkov S.Yu., Domrachev G.A., Kremlev K.V., Gusev S.A., Perevezentsev V.N., Moskvichev A.N., Moskvichev A.A., Rodionov A.S. Macroscopic cylinders on the basis of radial-oriented multi-wall carbon nanotubes, 2012, Letters on Materials, Vol. 2, pp. 152-156.

[2] Kremlev K.V., Ob'edkov A.M., Ketkov S.Yu., Kaverin B.S., Semenov N.M., Gusev S.A., Tatarskii D.A., Yunin P.A. Pyrolytic Deposition of Nanostructured Titanium Carbide Coatings on the Surface of Multiwalled Carbon Nanotubes // Technical Physics Letters, 2016, Vol. 42, No. 5, pp. 517–519.

50. FORMATION OF FRACTAL CRYSTALS ON STEEL SURFACE

A. Burtsev¹, D. Bukharov¹, E. Pritotsky^{1,2}, A. Pritotskaya^{1,2},
M. Shakhov¹, N. Aganin¹, O. Butkovsky¹

¹Vladimir State University named after Alexander and Nikolay Stoletovs, 600000, Russia

²State Laser Proving Ground "Raduga", 600910, Russia

In this paper it is demonstrated experiments and model researching of the formation of fractal crystals on steel surface by the pulse laser radiation heating. Results of electron scanning microscopy and forge microscopy demonstrated that fractal crystals grow on the steel surface layer after laser heating. The parameters of fractal crystals (dendrites and spherulites) forming are determined by experiments. The thickness of the melt layer and the possibility of the fractal morphology forming on the surface were calculated.

Modification of a surface of metals by laser radiation is one of the important tasks in fundamental science and in applied engineering [1,2]. Formation of varied morphological structures has application as designing structures with new properties. We can control these properties by fixing laser beam parameters and selecting material. In the previous papers [3-5] authors described modification of a stainless steel surface by the laser heating of two laser equipments. In paper [4] it was succeeded to obtain fractal crystals on a surface (stochastic dendrites) and to connect their distribution with energy gradients of laser pulse shape. Interesting results of researching fractal crystals in metals are published at [6], but crystals have spin-like form (spherulite). Origin of steady crystallization centers and stabilized growth of a dendritic crystal was considered in papers [7,8]. In particular, it was specified that high rates of melting overcooling are necessary for stabilized growing of a dendrite.

On the surface layer authors designed fractal crystals of two types: stochastic dendrites and spin-like spherulites. Each type of crystals has particular chemical composition. Modeling of crystallization centers distribution and stabilized growth were simulated by cellular automata (Conway's "Life" [9] and diffusion-limited aggregation [10]). These models can be used for simulation of different distribution and particular crystal growth.

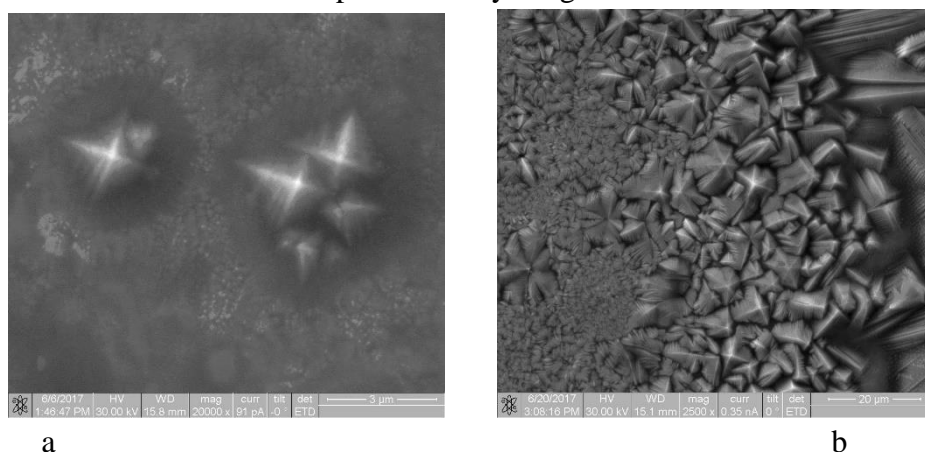

Pic. 1. a) Fractal (dendritic) crystal on steel surface,
b) Close-centered crystallization: different fractal crystals (dendrites and spherulites).

[1] Делоне Н.Б. Взаимодействие лазерного излучения с веществом. – Москва, 1989. – 280с.

- [2] Звелто О. Принципы лазеров: Пер. с англ. – 3-е изд. – М.: Мир, 1990. – 560 с.
- [3] Антонов Д.Н., Бурцев А.А., Бутковский О.Я. Окрашивание поверхности металлов под действием импульсного лазерного излучения // Журнал технической физики. 2014. Т. 84. Вып. 10. С. 83-86.
- [4] Антонов Д.Н., Бурцев А.А., Бутковский О.Я. Распределение дендритов, получаемых на поверхности стали в результате воздействия лазерного излучения // Журнал технической физики. 2016. Т. 86. Вып. 1. С. 110-115.
- [5] Бурцев А.А., Бутковский О.Я., Сагитова А.В., Мешков Г.Б., Яминский И.В. Исследование процесса образования фрактального кристалла // Тезисы доклада XII Всероссийской конференции «Наноэлектроника, нанофотоника и нелинейная физика» // Саратов: Изд-во “Техно-Декор”. 2017. С. 22-24.
- [6] Галенко П.К., Харанжевский Е.В., Данилов Д.А. Высокоскоростная кристаллизация конструкционной стали при лазерной обработке поверхности // Журнал технической физики. 2002. Т. 72. Вып. 5. С. 48-55.
- [7] Харанжевский Е. В., Кривилёв М.Д., Галенко П.К. Физика лазеров, лазерные технологии и методы математического моделирования лазерного воздействия на вещество. - Ижевск: Изд-во “Удмуртский университет”, 2011. - 187 с.
- [8] Galenko P., Jou D. Diffuse-interface model for rapid phase transformations in nonequilibrium systems // Phys. Rev. E, 17 (2005) 046125-1-13.
- [9] Gardner M. The Fantastical Combinations of John Conway’s New Solitaire Game “Life”. // Scientific American 223 9(4) – 1970. – p.120-123.
- [10] Witten T.A., Sander L.M. Diffusion limited aggregation. // Physical Review B. – 1983. - V. 27. – №.9. – p. 5686-5697.

51. EFFICIENT FREQUENCY DOUBLING ON WITH THE THREE-MIRROR RESONATOR

E. Pritotsky^{1,2}, S. Lysenko², M. Pankov^{1,2}

¹*Vladimir State University named after Alexander and Nikolay Stoletovs, 600000, Russia*

²*State Laser Proving Ground "Raduga", 600910, Russia*

Obtaining high peak power of visible radiation of the solid-state laser with diode lasers bar (DLB) pumping is relevant for a number of applications: precise processing of materials, non-linear optics, Raman scattering, medicine, etc. Modulation of good quality of the resonator of the laser allows to increase peak power of radiation, for typical Nd:YAG laser this increase makes $10^3 - 10^4$ times. Recently by science team it was published a number of the works devoted to an efficient frequency doubling and increases in peak power, in particular [1]. For transformation of the generated radiation to the second harmonica with a peak efficiency usually use the scheme on three or more mirrors with transformation of radiation in the resonator [2]. The simple scheme of an efficient frequency doubling of the Nd:YAG-laser with a transversal rating the DLB and with a non-linear crystal is submitted in the picture 1.

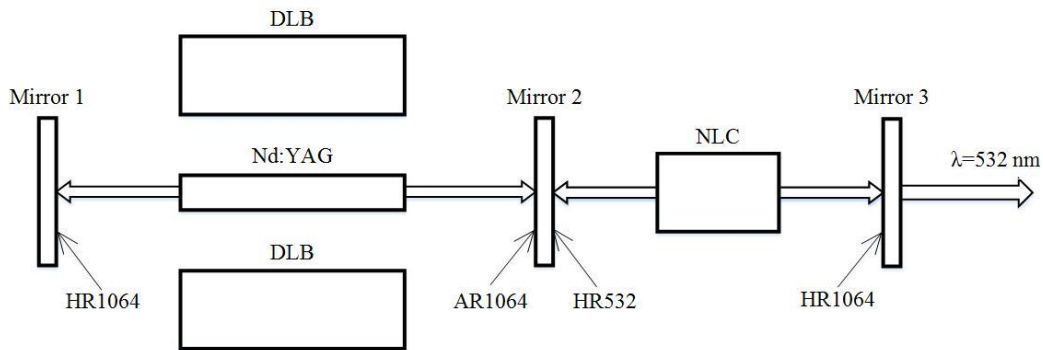

Pic. 1. The experimental scheme of the laser with the three-mirror resonator

The reflection of mirrors 1 and 3 more than 99% on a wavelength $\lambda_1=1064 \text{ nm}$, at the same time a mirror 3 passes radiation with a wavelength $\lambda_2=532 \text{ nm}$ with coefficient of 90%. The mirror 2 is dichroic: reflection more than 99% on a wavelength $\lambda_2=532 \text{ nm}$ and a transmittance more than 99% on a wavelength $\lambda_1=1064 \text{ nm}$. For obtaining radiation the non-linear crystal is located on the second harmonica between mirrors 2 and 3. At the same time the Nd:YAG element has the antireflective coatings on sides on a wavelength $\lambda_1=1064 \text{ nm}$, and the non-linear crystal has the antireflective coatings on sides on lengths of waves $\lambda_1=1064 \text{ nm}$ and $\lambda_2=532 \text{ nm}$, a residual reflectivity on elements no more than 1%.

At such scheme the generated power on the main wavelength $\lambda_1=1064 \text{ nm}$ is locked in the resonator and gradually the value of a power density to necessary for transformation of radiation to the second harmonica increases. Adjustment of power is made due to selection of a transmittance of a mirror 3 on a wavelength $\lambda_2=532 \text{ nm}$. Such scheme places great demands not only on optical characteristics of coatings, but also on their laser-induced damage threshold therefore coatings represent the alternating thin dielectric layers of high-pure oxides of silicon or refractory metals, and optical characteristics calculate beforehand for the choice of an optimum design of a coating and precise monitoring of dusting of each layer. Optical characteristics of the coatings received by us disperse with calculated no more, than for 1%, that corresponds to error of spectrophotometers.

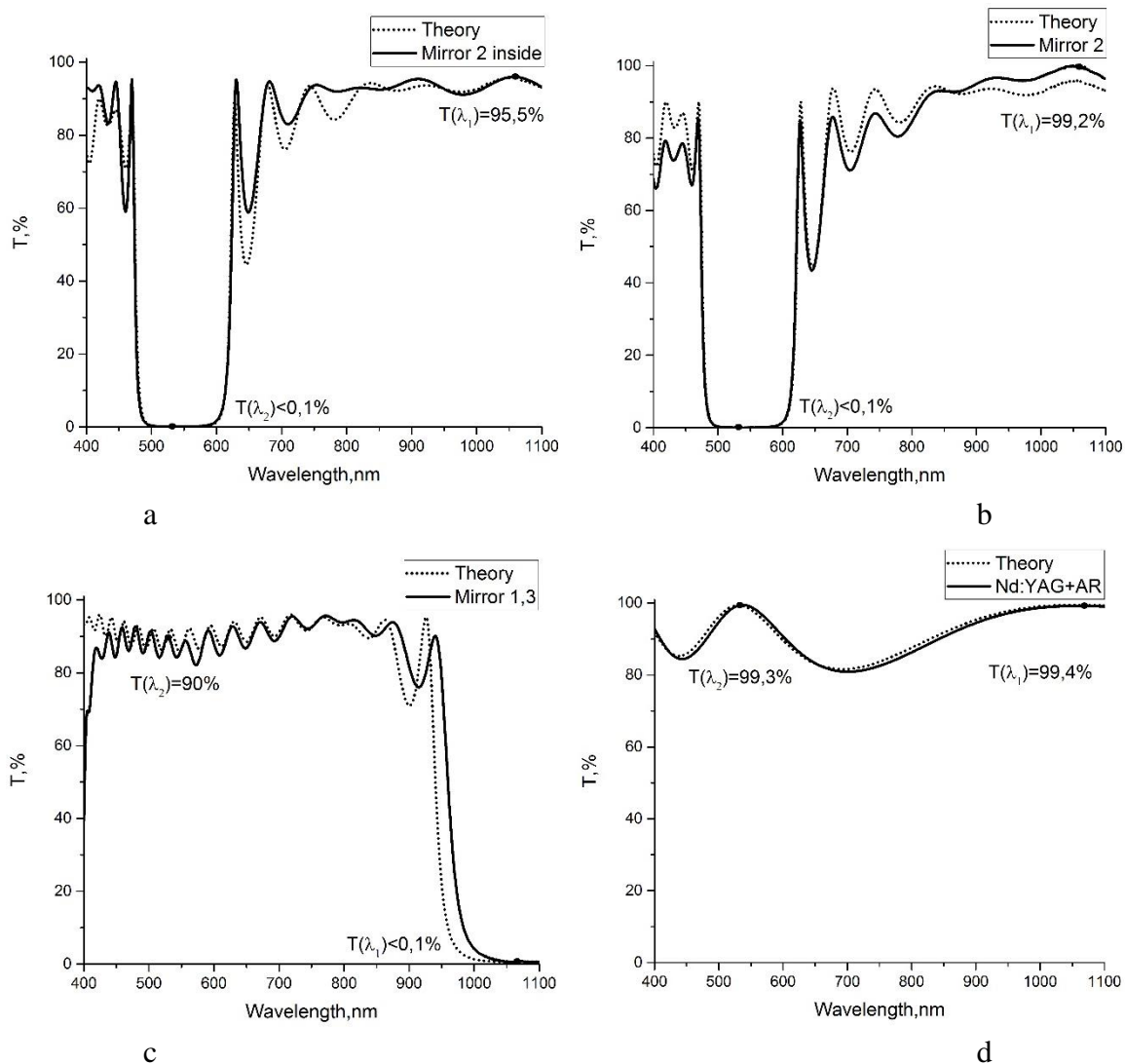

Pic. 2. Plots of dependence of transmittance from wavelength: design and actual transmittance on inside of mirror 2 (a), design and actual transmittance with antireflection coating on outer side of mirror 2 (b), design and actual transmittance of mirror 1,3 (c), design and actual transmittance of antireflection coating on Nd:YAG (d)

[1] В. И. Донин, Д. В. Яковин, А. В. Грибанов, Модуляция добротности и синхронизация мод в диодно-накачиваемом Nd : YAG-лазере с удвоением частоты // Квантовая электроника, 2012, том 42, номер 2, 107–110

[2] В. И. Донин, А. В. Никонов, Д. В. Яковин, Эффективное удвоение частоты в Nd:YAG-лазере с поперечной диодной накачкой // Квантовая электроника, 2004, том 34, номер 10, 930–932

52. PHYSICAL PROPERTIES OF NANODEFECTED SURFACE THIN-FILM STRUCTURE

A. Burtsev¹, E. Pritotsky^{1,2}, M. Pankov^{1,2}

¹Vladimir State University named after Alexander and Nikolay Stoletovs, 600000, Russia

²State Laser Proving Ground "Raduga", 600910, Russia

The development of techniques and the creation of new magneto- and optoelectronic elements based on thin semiconductor films with ultrathin metal coatings with the possibility of modifying their surface is one of the most important problems in fundamental science and engineering. A consequence is able to change in the physicochemical, electro physical and optical properties and the manifestation of quantum-size effects. Quantum-dimensional effects on the surface of semiconductor with doped metal layer have relatively large dimensions for the diagnosis and study of dimensional effects over a wide range [1]. A main characteristic is ability to change the semiconductor surface with the formation of nanodefected by a controlled influence types. Imperfections, such as impurities or defects, can localize electronic states, which in turn can generate narrow bands, a Mott transition and even Anderson localization.

As an approximation to modeling, the properties of the surface structure with nanodefected it can be used the models of fractal clustering on 2 dimensions [2]. Cellular automata, such a percolation approximation or diffusion-limited aggregation are examples of mentioned clustering models. Within these models, we can model structures of isolated and interfacing clusters.

The methods of percolation and diffusion clustering show that the increase in permeability increases the fractal dimension, which in turn leads to an increase its size-properties [3]. Determination of the parameters of methods for depositing and modifying the surface layer will allow the formation of a cluster with the fixing size and properties. In the future, this will open up the possibility of creating morphology with controllable point defects for the modulation of optical radiation.

[1] Kovalevsky A.A., Strogova A.S., Strogova N.S., Babushkina N.V. Investigation of Electrical Properties of MOS Structures with Silicon Nitride Films Doped with Rare Earth Elements // Russian Microelectronics. 2014. Vol. 43. - No. 4. Pp. 246–251

[2] Wugang Liao, Xiangbin Zeng, Xixing Wen, Wenjun Zheng, Yangyang Wen, Wei Yao. Characteristics and Charge Storage of Silicon Quantum Dots Embedded in Silicon Nitride Film. // Journal of ELECTRONIC MATERIALS. 2015. Vol. 44. - No. 3. Pp.1015-1020.

[3] Shuxian Wang , Haohai Yu , Huaijin Zhang etc. Broadband Few-Layer MoS₂ Saturable Absorbers. Advanced Materials. 2014, p. 1-7.

53. FORMATION OF THE CHROMATICITY ON STEEL SURFACE

E. Pritotsky^{1,2}, A. Pritotskaya^{1,2}, A. Burtsev¹, O. Butkovsky¹

¹*Vladimir State University named after Alexander and Nikolay Stoletovs, 600000, Russia*

²*State Laser Proving Ground "Raduga", 600910, Russia*

Experimental researches of chromaticity formation on the surface of stainless steel by pulse laser radiation are presented. It is made a calculation of dependence of coefficient of reflection on wavelength in the visible range and thickness of an oxidic film on a surface of the marked surface. Influence of thickness of an oxidic film on the formed color of a surface at the expense of an interference on the system of films of oxide of iron and iron is shown [2]. It is shown the process of increase in a hade function of reflection is displaced to the left and its amplitude decreases. By results of scanning electron microscope significant increase in content of oxygen in places of influence is recorded that indicates formation of oxidic films. The analysis of a profile of the metals of oxidic films received on a surface is carried out and the dependence of chromaticity of the modified surface on parameters of laser radiation is shown [2]. On the example of stainless steel the technology of color laser marking of a surface of metals which allows to change their optical properties in a visible band is considered [3-6]. The conclusions received on models were confirmed by the experiments made by authors on laser color marking of stainless steel during which pronounced colors turned out: from blue to pink. By results of a scanning electron submicroscopy the significant increase in content of oxygen in places of influence is recorded that indicates formation of oxide layers.

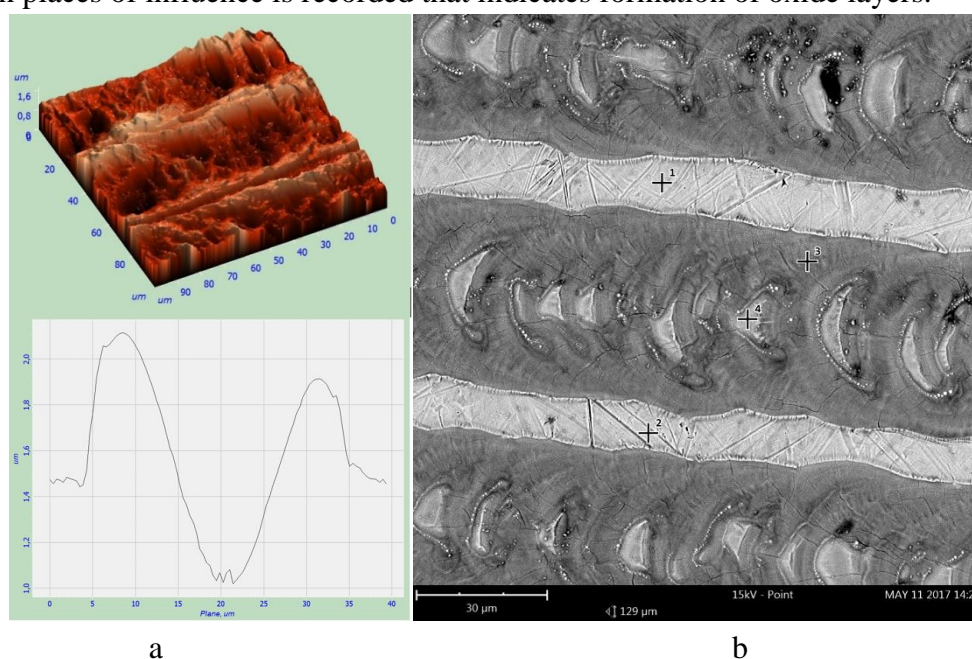

Pic. 1. a) AFM-image of steel surface, b) SEM-image, point number is marking measurement of chemical concentration of O₂ 1) 30,3%, 2) 36,8%, 3) 60,2%, 4) 48,8%.

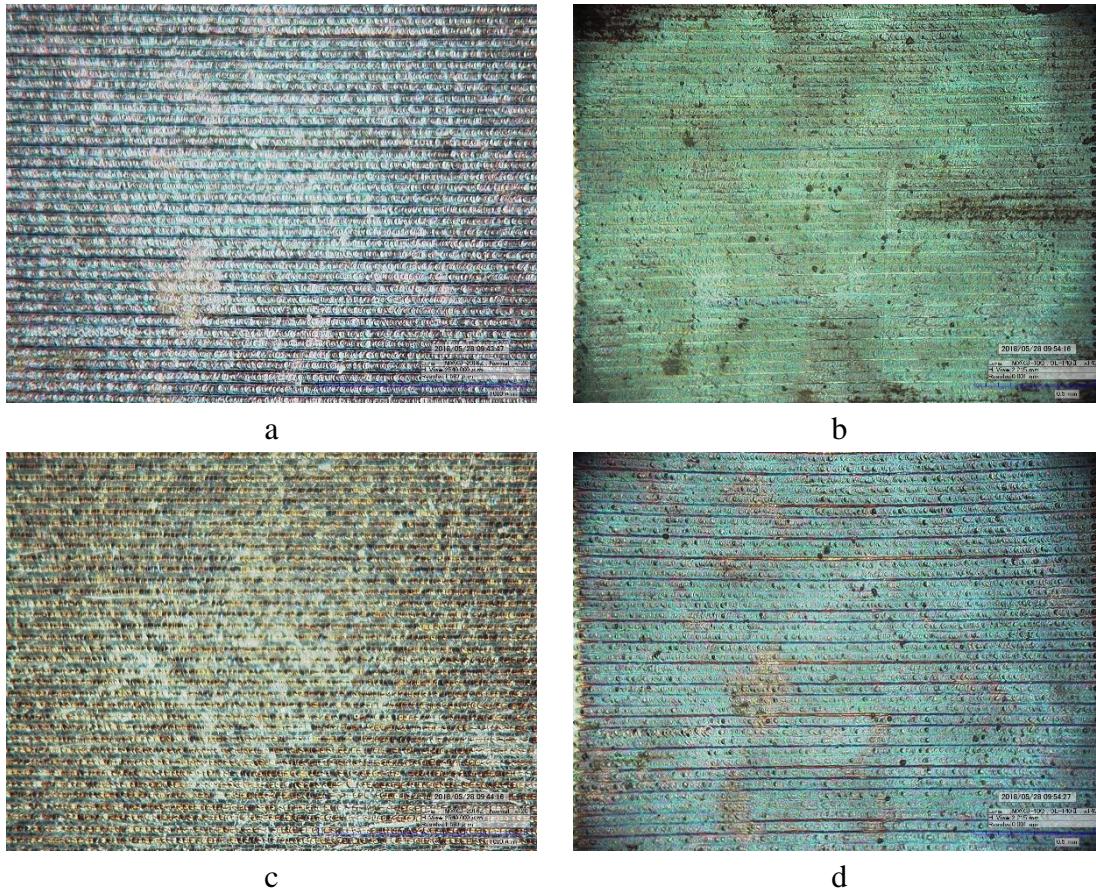

Pic. 2. Photos 3×2,25 mm of the received colors on a surface of examples:
pink (a); green (b); yellow (c), blue (d)

- [1] Антонов Д.Н., Бурцев А.А., Бутковский О.Я. Окрасивание поверхности металлов под действием импульсного лазерного излучения // Журнал технической физики. 2014. Т. 84. Вып. 10. С. 83–86.
- [2] Притоцкий Е.М., Притоцкая А.П., Бурцев А.А., Панков М.А., Бутковский О.Я., Аракелян С.М. Экспериментальные исследования по формированию цветности на поверхности металлов лазерным излучением // Научно-технический вестник информационных технологий, механики и оптики. 2018. Т. 18. № 4. С. 581–587.
- [3] Валиулин А., Горный С., Гречко Ю., Патров М., Юдин К., Юревич В. Лазерная маркировка материалов // Фотоника. 2007. № 3. С. 16–23.
- [4] Горный С., Вейко В., Одинцова Г., Горбунова Е., Логинов А., Карлагина Ю., Скуратова А., Агеев Э. Цветная лазерная маркировка // Фотоника. 2013. № 6. С. 34–44.
- [5] Veiko V. et al. Controlled oxide films formation by nanosecond laser pulses for color marking // Optics express. 2014. V. 22. N 20. P. 24342–24347.
- [6] Łęcka K.M., Wójcik M.R., Antończak A.J. Laser-Induced Color Marking of Titanium: A Modeling Study of the Interference Effect and the Impact of Protective Coating // Mathematical Problems in Engineering. 2017. V. 2017.

54. FORMATION OF CHANNELS WITH CHANGED REFRACTIVE INDEX AT THE FILAMENTATION OF FEMTOSECOND LASER RADIATION IN QUARTZ GLASS

M. Tarasova, K. Khorkov, D. Kochuev, V. Prokoshev, A. Ivaschenko

*Department of Physics and Applied Mathematics,
Vladimir State University named after A. G. and N. G. Stoletovs, 87 Gorky, Vladimir,
600000, Russia*

E-mail: trsvmargarita@gmail.com

The paper deals with the phenomenon of filamentation in the propagation of femtosecond laser radiation in transparent solid media. The sample was structured in the filamentation mode, which allows obtaining a given distribution of the laser radiation intensity.

The source of laser radiation was the ytterbium femtosecond laser TETA-10 (wavelength 1029 nm, pulse duration 280 fs, pulse repetition rate 10 kHz, maximum pulse energy 150 μ J). Quartz glass was used as a sample.

The filamentation of femtosecond laser radiation results in a redistribution of intensity in the transverse beam profile. The passage of high-intensity radiation through the sample forms areas with a changed refractive index in the places of self-localization of laser radiation. In the future, the formation of filaments occurs in modified areas. Thus, when the laser radiation passes through the modified sample, the intensity redistribution occurs in accordance with the spatial position of the changed areas.

The experiment on modification of the sample using the phenomenon of multiple filamentation [1] was carried out. The scheme of the experiment is shown in Fig.1.

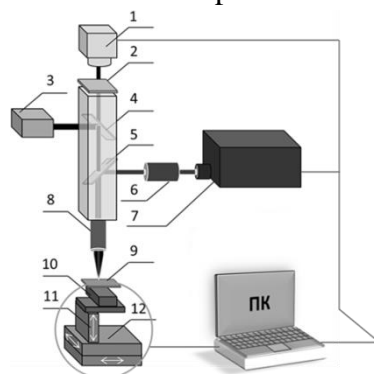

Fig.1. Scheme of the experiment

The laser radiation of a femtosecond laser system 7 passed through a polarization attenuator 6 [2]. Then the radiation was reflected from the dichroic mirror 5 and focused into the sample 9 with the help of the focusing lens 8. The sample was moved using the XYZ platform 11-12 and the motorized drive 10. The adjustment of the focusing area and the visualization of the obtained results were carried out with the help of the camera 1 and the backlight 3 (2-filter). The trajectory of the sample was set using a computer program. The radiation power was 600 mW, the velocity of the beam relative to the sample was 50 μ m/s. To visualize the formed structures, the sample was illuminated by ultraviolet radiation with a wavelength of 257 nm, which was obtained from the frequency converter block. Ultraviolet radiation, falling into a sample of quartz glass, caused the luminescence of the formed structures. Fig. 2 shows the optical structures in the illumination by UV radiation.



Fig.2. Optical structures in illumination by UV radiation

Fig. 3 shows the redistribution of intensity, when laser radiation with a wavelength of 1029 nm passes through the entire volume of the modified sample without the use of a focusing lens.

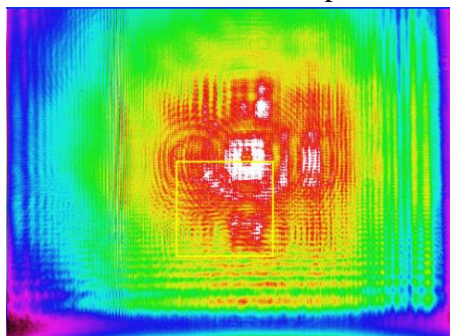

Fig.3. Redistribution of intensity

Thus, the paper studies the process of intensity redistribution in filamentation of femtosecond laser radiation, which allows forming extended channels with a modified refractive index. By controlling the spatial position of the channels, it is possible to obtain a predetermined intensity distribution. This solution has a wide range of practical applications when using various laser technological operations.

- [1] Tarasova M.A., Khorkov K.S., Kochuev D.A., Ivashchenko A.V. Investigation of the phenomenon of laser radiation filamentation // Bulletin of the Lebedev Physics Institute. 2018. V. 8. P. 33-40.
- [2] Chernikov A.S., Khorkov K.S., Kochuev D.A., Chkalov R.V. Modification of the refractive index in non-photosensitive optical fibers by femtosecond laser radiation // Proceedings of the International Scientific and Technical Conference. Editorial and Publishing Department of MIREA, 2017. P. 176-179.

**55. МОДИФИКАЦИЯ СКОРОСТИ ГЕНЕРАЦИИ ПОВЕРХНОСТНЫХ
ПЛАЗМОН-ПОЛЯРИТОНОВ ВОЗБУЖДЕННЫМИ
ПОЛУПРОВОДНИКОВЫМИ КВАНТОВЫМИ ТОЧКАМИ ВБЛИЗИ
МЕТАЛЛИЧЕСКОЙ ПОВЕРХНОСТИ**

А. Шестериков¹, М. Губин¹, М. Гладуш², А. Прохоров¹

¹*Владимирский государственный университет им. А.Г. и Н.Г. Столетовых, 600000,
Владимир*

²*Институт спектроскопии РАН, 108840, Москва, Троицк
Тел.: +7(910)7773068., e-mail: avprokhorov33@mail.ru*

Рассмотрим модель, состоящую из золотой металлической поверхности с нанесенной на нее диэлектрической пленкой (полиэтилентерефталат), содержащей сферические квантовые точки (КТ) на основе полупроводника CdSe (рис. 1а.). Для возбужденной КТ вблизи металлического зеркала скорость развития релаксационных процессов будет в значительной мере определяться размерными эффектами и иметь сильную зависимость от радиуса a КТ и ее расстояния d до металлической поверхности. Задача сводится к оптимизации параметров a и d для достижения максимальных значений скорости преобразования энергии возбужденной КТ в поверхностные плазмон-поляритоны (ППП) на заданной частоте.

В ситуации, когда дипольный момент КТ ориентирован перпендикулярно поверхности зеркала выражение для относительной скорости релаксации $b_{\perp} = \tau/\tau_0$ (τ – скорость релаксации в присутствии металлического зеркала, τ_0 – без него) принимает следующий вид [1]:

$$b_{\perp} = 1 + \frac{3}{2} q \operatorname{Im} \left(\int_0^{\infty} F du \right), \quad (1)$$

где $F \equiv r_p \exp\left(\left(-4\pi\sqrt{\varepsilon_1} l_1 d\right)/\lambda_0\right) \left(u^3/l_1\right)$, q – квантовый выход и введены коэффициенты $r_p = (\varepsilon_2 l_1 - \varepsilon_1 l_2)/(\varepsilon_2 l_1 + \varepsilon_1 l_2)$ (амплитудный коэффициент отражения p -поляризованного света Френеля от толстого слоя металла) и $l_j = -i\sqrt{(\varepsilon_j/\varepsilon_1) - u^2}$. Здесь ε_1 – диэлектрическая проницаемость диэлектрика, $\varepsilon_2 = \varepsilon_2' + i\varepsilon_2''$ – комплексная функция диэлектрической проницаемости металла на длине волны λ_0 флуоресцирующей КТ; переменная интегрирования $u = k/k_0$ представляет собой нормированный на $k_0 = 2\pi/\lambda_0$ волновой вектор.

Для моделирования были выбраны КТ с размерами, при которых частота только одного межзонного перехода $1S(e) \rightarrow 1S(h)$ в КТ попадает в область так называемого плазмонного пика [1, 2] и может быть определена следующим образом:

$$\omega_0 = \frac{1}{\hbar} \left(eE_g + \frac{\hbar^2 \pi^2}{2a} \left(\frac{\chi_{n'l}^2}{m_e} + \frac{\chi_{n'l}^2}{m_h} \right) - \frac{3.56e^2}{8\pi\varepsilon\varepsilon_0 a} \right), \quad (2)$$

где $m_e(m_h)$ – эффективные массы электрона (дырки), $\chi_{n'l}$ – корни сферического уравнения Бесселя 1-го рода, E_g – ширина запрещенной зоны полупроводника КТ, e – заряд электрона, ε – диэлектрическая проницаемость материала КТ, a – радиус КТ. Распределение энергии

между излучательным и безизлучательным каналами релаксации зависит от вида подинтегральной функции F в (1) с возможностью управления через варьирование параметров a и d (см. рис.1б). Для решения задачи оптимизации введем параметр интегральной вероятности передачи запасенной КТ энергии в ППП в виде $w_p = \frac{b_{sp}}{b_{\perp}}$ [1], где

$$b_{sp} = \frac{3qA\pi u_{sp}^3}{2Bl_{sp1}} \exp\left(\frac{-4\pi\sqrt{\varepsilon_1}l_{sp1}d}{\lambda_0}\right), \quad (3)$$

и при условии $\varepsilon_2'' \ll -\varepsilon_2'$ имеем $A = \left((2l_{sp2}\varepsilon_1 - (\varepsilon_2'/l_{sp2}))l_{sp1}^3 l_{sp2}^2 \varepsilon_2'' \right) / \left((\varepsilon_1 l_{sp1} + \varepsilon_2' l_{sp2})^2 u_{sp}^2 \right)$, $B = \left((l_{sp1}^2 l_{sp2} - (l_{sp1}/2)) \varepsilon_2'' \right) / \left((\varepsilon_1 l_{sp1} + \varepsilon_2' l_{sp2}) u_{sp} \right)$, $l_{spi} = \sqrt{u_{sp}^2 - \text{Re}(\varepsilon_i) / \varepsilon_1}$, $i=1, 2$. На рис.1б представлена контурная зависимость параметра w_p от радиуса КТ и ее расстояния до металла. Нанесенная на рисунок черная линия соответствует максимальным значениям w_p , найденным оптимизацией по параметру d . Наибольшие значения $w_p \approx 0.997$ достигаются для изготовленных из CdSe КТ с радиусом $a \approx 2$ нм, размещенных на расстоянии $d \approx 69$ нм от золотой поверхности. Рабочая длина волны составит $\lambda_0 = 497$ нм, длина затухания генерируемых ППП равна 21 мкм. При этом, снижение скорости генерации ППП при удалении КТ от поверхности может быть частично компенсировано увеличением длины волны λ_0 межзонного перехода при использовании КТ большего радиуса (2).

Однако возможности такой компенсации ограничены наличием горизонтальной асимптоты $\omega_0 = eE_g / \hbar$ в (2) и, начиная с $a \approx 6$ нм, система становится слабо чувствительной к размерным эффектам для КТ. С учетом успехов в области создания и диагностики КТ [3], а также проектирования плазмонных интерфейсов [4], полученные результаты должны быть востребованы для создания высокоэффективных генераторов ППП. Вместе с тем, реализация описываемых моделей на практике требует учета дисперсионных эффектов [5].

Работа поддержана грантом РФФИ 16-02-01174 а и выполнена в рамках государственного задания ВлГУ 3.5531.2017/8.9 (ГБ-1106/17).



Рис. 1. а) Схематичное изображение КТ вблизи границы раздела металлической и диэлектрической поверхностей с выделенными тремя основными каналами релаксации КТ в I) свет, II) ППП, III) фононы; б) Контурная зависимость параметра эффективности w_p преобразования энергии КТ в ППП от радиуса КТ a и расстояния d КТ до металлического зеркала с нанесённой линией экстремума. Расчёт параметра b_{\perp} производился численно с использованием метода замены переменных.

- [1] *Weber W.H., Eagen C.F.* Energy transfer from an excited dye molecule to the surface plasmons of an adjacent metal // *Opt. Lett.* 1979. V. 4, N 8. P. 236 – 238.
- [2] *Xiao M., Bozhevolnyi S.I., Keller O.* Numerical study of configurational resonances in near-field optical microscopy with a mesoscopic metallic probe // *Appl. Phys. A.* 1996. V. 62, N 2. P. 115 – 121.
- [3] *Magaryan K.A., Mikhailov M.A., Karimullin K.R., et. al.* Spatially-resolved luminescence spectroscopy of CdSe quantum dots synthesized in ionic liquid crystal matrices // *J. Lumin.* 2016. V. 169. P. 799 – 803.
- [4] *Birr T., Zywietz U., Fischer T., Chhantyal P., Evlyukhin A.B., Chichkov B.N., Reinhardt C.* Ultrafast surface plasmon-polariton interference and switching in multiple crossing dielectric waveguides // *Appl. Phys. B.* 2016. V. 122, N 6. P. 164.
- [5] *Губин М.Ю., Гладуш М.Г., Прохоров А.В.* Конфигурационный резонанс и скорость генерации поверхностных плазмон-поляритонов возбужденными полупроводниковыми квантовыми точками вблизи металлической поверхности // *Оптика и спектроскопия.* 2019. №1, С. 77.

56. LASING CHARACTERISTIC OF LASER CERAMICS

M. Pankov^{1,2}, S. Lysenko², A. Kanaev², A. Kiselev², A. Antipov^{1,2}

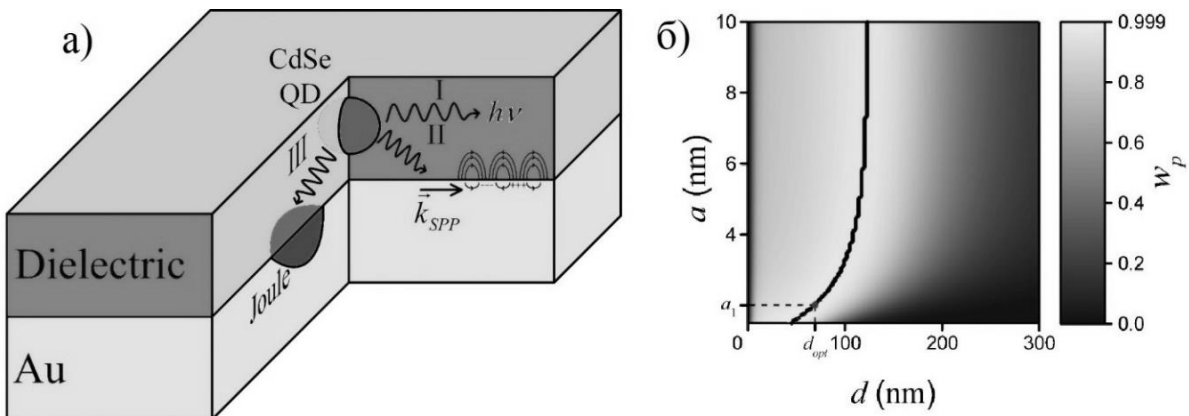
¹Vladimir State University named after Alexander and Nikolay Stoletovs, 600000, Russia

²State Laser Proving Ground "Raduga", 600910, Russia

mpa.off@gmail.com

Lasing efficiency of neodymium-doped yttrium – aluminium garnet (YAG) ceramic samples, which were fabricated at the Fryazino Branch of the Kotelnikov Institute of Radio Engineering and Electronics, Russian Academy of Sciences and the SLPG ‘Raduga’ in 2016 – 2017, is studied under the conditions of end- and side-pumping.

The efficiency of lasers based on this ceramics was 64 % in the case of end-pumping and 68 % – 70 % upon side-pumping. The laser level lifetimes are measured in ceramics with neodymium concentrations of 1, 2, 3, and 4 at %. The measured lifetimes well agree with the literature data. The dependences of the lasing threshold on the cavity length under the conditions of transverse mode locking and diode end-pumping are studied for different samples of laser ceramics in a semiconfocal cavity. In sum, the performed investigations showed that the quality of the first industrial samples of Russian laser ceramics are highly competitive in quality with the ceramics produced by Konoshima Chem. Corp., Ltd., which is considered by the laser community as an etalon.

CONFERENCE INFORMATION AND CONCLUSION

Organizers

- Stoletovs Vladimir State University, Vladimir, Russia
- Institute of laser physics SB RAS, Novosibirsk, Russia
- International Laser Center of M.V. Lomonosov Moscow State University

Supported by

- Ministry of Education and Science of the Russian Federation
- Russian Foundation for Basic Research

Conference Chairman

Kavokin Alexey – Ph.D., Prof., Institute of Natural Sciences, Westlake University

Chairman of the Organizing Committee

Arakelian Sergey - Head of the Department of Physics and Applied Mathematics Vladimir State University, Dr.Sc., Prof, Chairman.

Program Committee

Kavokin Alexey – Ph.D., Prof., Chair of Nanophysics and Photonics, University of Southampton

Kucherik Alexey. - leading researcher of the Department of Physics and Applied Mathematics Vladimir State University, PhD, Scientific Secretary.

Tigran Vartanyan - Chief Researcher, University ITMO, Dr.Sc., Prof.

Veiko Vadim - Head of the Department of laser technology and laser technology ITMO University, Dr.Sc., Prof.

Garnov Sergey - Director of General Physics Institute RAS, corresponding member of RAS, Dr.Sc., Prof.

Zadkov Viktor - Director of the Institute of Spectroscopy, RAS, Dr.Sc., Prof.

Makarov Vladimir - Head of the Department of General Physics and Wave Processes, Director of the ILC MSU. Dr.Sc., Prof.

Ryabtsev Igor - Head of the Laboratory of nonlinear resonant processes and laser diagnostics ISP SB RAS, corresponding member of RAS, Dr.Sc., Prof.

Taichenachev Alexey -Director ILP SB RAS, corresponding member of RAS, Dr.Sc., Prof.

Shkurinov Alexander - prof. Department of General Physics and Wave Processes MSU., Dr.Sc., Prof.

Suzdal



КОНФЕРЕНЦИЯ
(Пушкарская слобода
ул. Ленина, 45)

- 2. Suzdal City Council, Lenin monument
- 3. Monument to those fallen in World War II
- 4. Suzdal Tourist Centre. Hotel, motel, restaurant
- 5. Hotel on the grounds of the former Convent of the Intercession. The former convent refectory houses the restaurant Trapeznaya
- 6. Restaurant Gostiny Dvor
- 7. Restaurant Trapeznaya in Suzdal Kremlin
- 8. Restaurant Pogrebok (cellar)
- 9. Souvenirs' store Suzdalskaya Lavka
- 10. Arcade of shops (19th century)
- 11. Coachman's Inn
- 12. Bus station
- 13. The Convent of the Intercession (16th-18th cent.)
Expositions: "From the History of the Convent", "Articles of Needlework", "Interior of the 17th-century Chancellor's House"

- 14. The Spaso-Yevfimievsky Monastery (16th-17th cent.)
Museum of the Amateur Works of Art of the Peoples of the Russian Federation. Exposition: Gold Treasure Trove
- 15. The 17th-century townsman's house. The Interiors of Living Home Exposition.
- 16. The Church of St Peter and St Paul (17th century) Wood Painting Exposition
- 17. The Monastery of the Deposition of the Robe (16th-19th cent.)
- 18. The Church of St Nicholas and the Holy Cross (18th century). Peasant Clothing Exhibition
- 19. The Church of the Resurrection (18th century) Exposition: Folk Wood Carving
- 20. Suzdal Kremlin (13th-18th cent.). Expositions: "Leninist Policy of Protecting the Monuments of History and Culture", "Early Russian Painting", "The Cross Chamber Interior"
- 21. The earthen rampart surrounding the Kremlin (12th cent.)
- 22. The open-air Museum of Wooden Architecture and Peasants' Everyday Life.

CONCLUSION

Считать 7-ую международную конференцию/школу-семинар "Современные нанотехнологии и нанофотоника для науки и производства" состоявшейся, удовлетворяющей вопросам современных нанотехнологий и лазерной физике и запланировать проведение следующей конференцию на 2019г.

Научное издание

СОВРЕМЕННЫЕ НАНОТЕХНОЛОГИИ И НАНОФОТОНИКА
ДЛЯ НАУКИ И ПРОИЗВОДСТВА

Материалы 7-й Международной конференции

8 – 12 ноября 2018 г.,
г. Владимир – г. Суздаль

Системные требования: Intel, AMD от 1,3 ГГц; Windows XP/Vista/7/8/10;
Adobe Reader; CD-ROM; 5 Мб; Загл. с титула экрана.

Материалы представлены в авторской редакции

За содержание статей, точность приведенных фактов и цитирование
несут ответственность авторы публикаций

Тираж 10 экз.

Владимирский государственный университет имени Александра Григорьевича
и Николая Григорьевича Столетовых

Изд-во ВлГУ

rio.vlgu@yandex.ru

Кафедра физики и прикладной математики

laser@vlsu.ru